

CP 2021

Fatigue fracture surface investigations with a 3D optical profiler

C. Santus*, P. Neri, L. Romoli, A. Lutey, S. Raghavendra, M. Benedetti



UniPi



UniTn



UniPr



Taylor Hobson CCI MP-L Optical Profiler

- Measurement type: 3D non-contact
- Measurement mode: Coherence Correlation Interferometry (CCI)
- Operating principle: Interference microscopy / fringe localization
- Camera resolution: 1 MP
- Sample surface reflectivity: <0.3% - 100%
- Z-scanner: Ultra high precision piezoless scanner
- Resolution in Z-direction: <1 nm
- X-, Y- and Z-stitching
- Software: Taylor Hobson TalySurf (data processing & ISO 25178-2 roughness parameters)

Objective	Field of view (mm)	Pixel size (μm)	Max. slope (°)	Working distance (mm)	Design
10×	1.73 × 1.73	1.7	8.6	7.4	Mirau
50×	0.346 × 0.346	0.34	27.5	3.4	Mirau



Mirau Interferometer

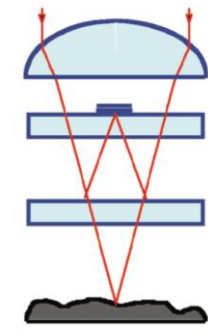

Magnification

10 X, 20 X, 50 X, 100 X

Fatigue fracture surface detection example

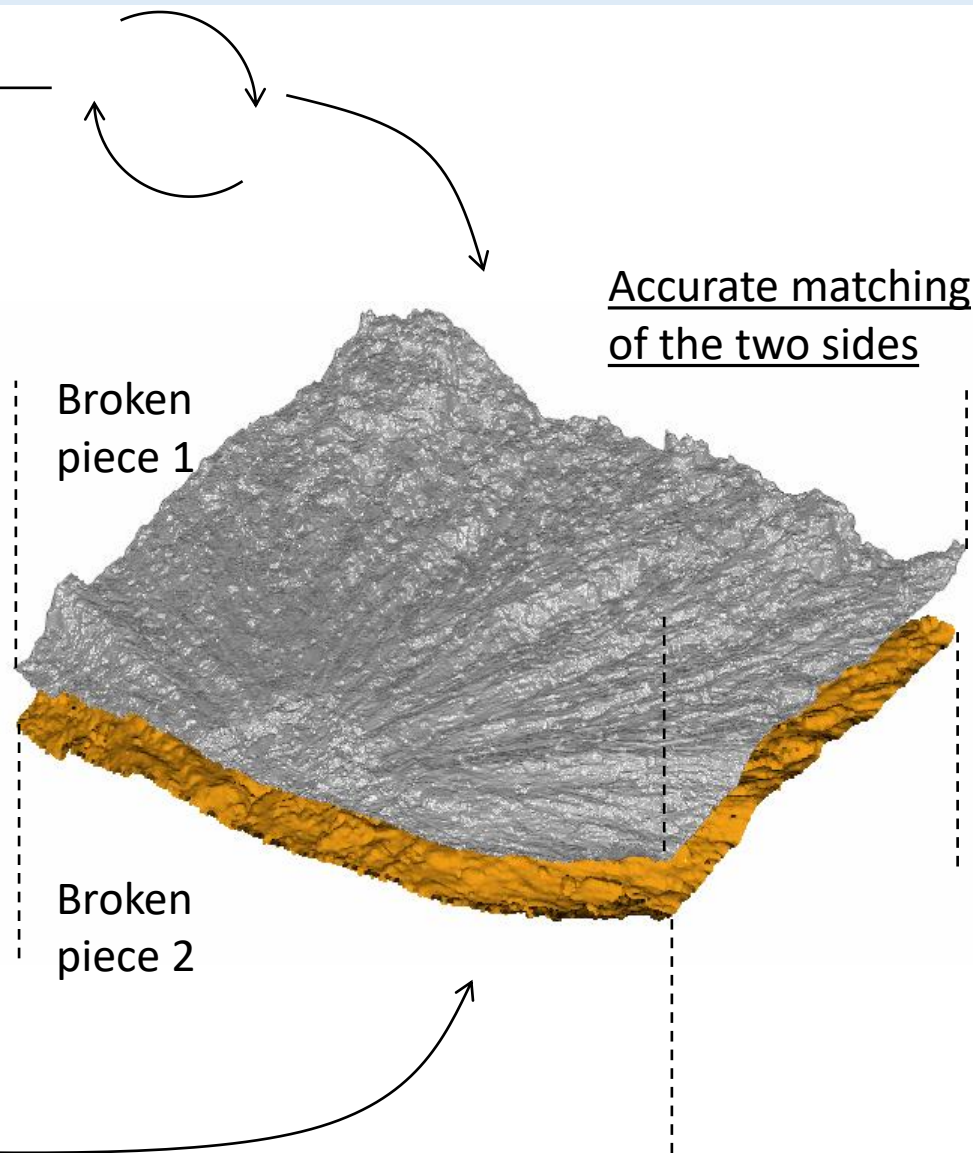
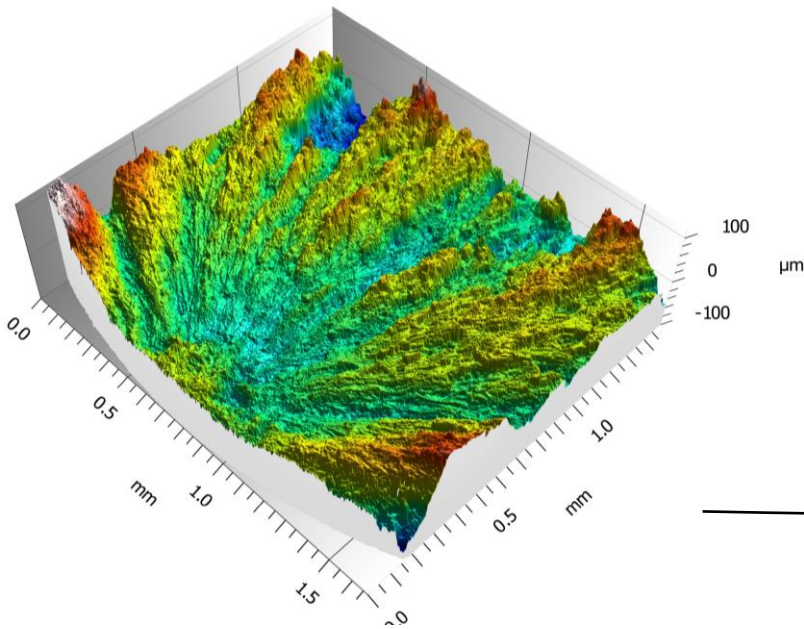
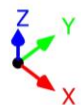
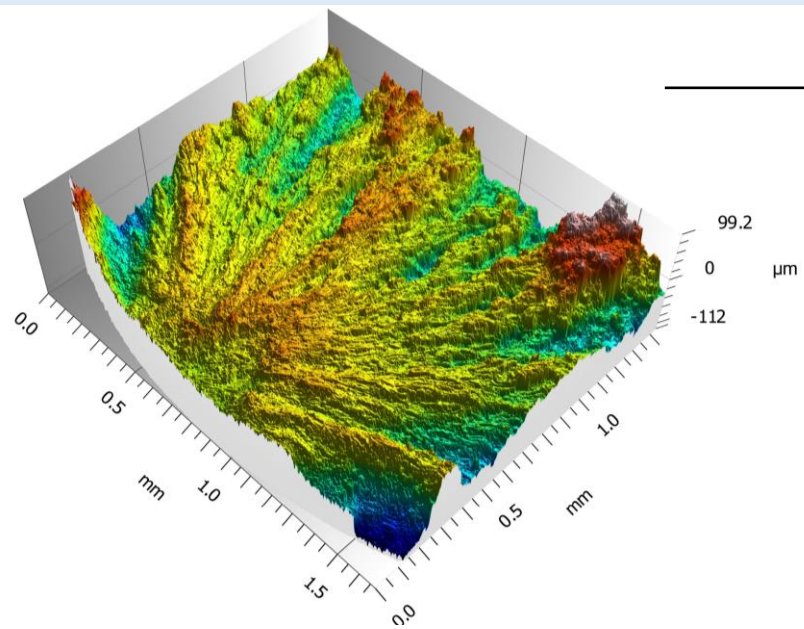
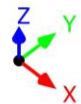
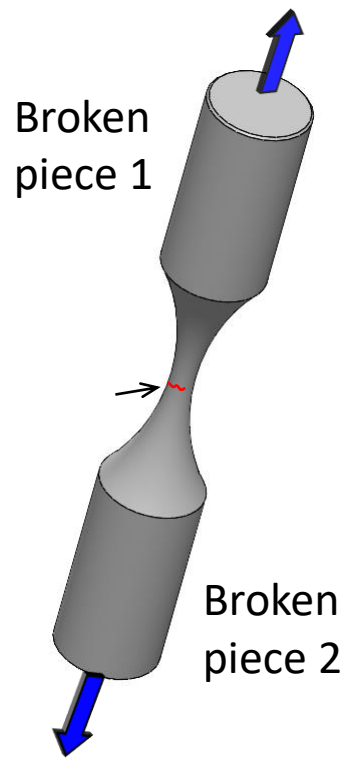
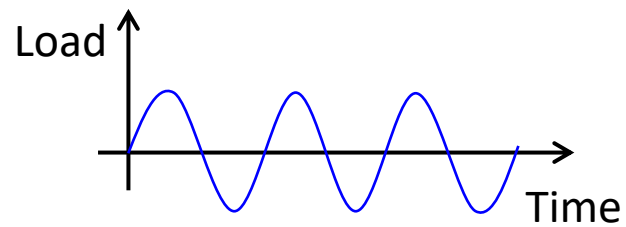

Critical distance determination, Mode I

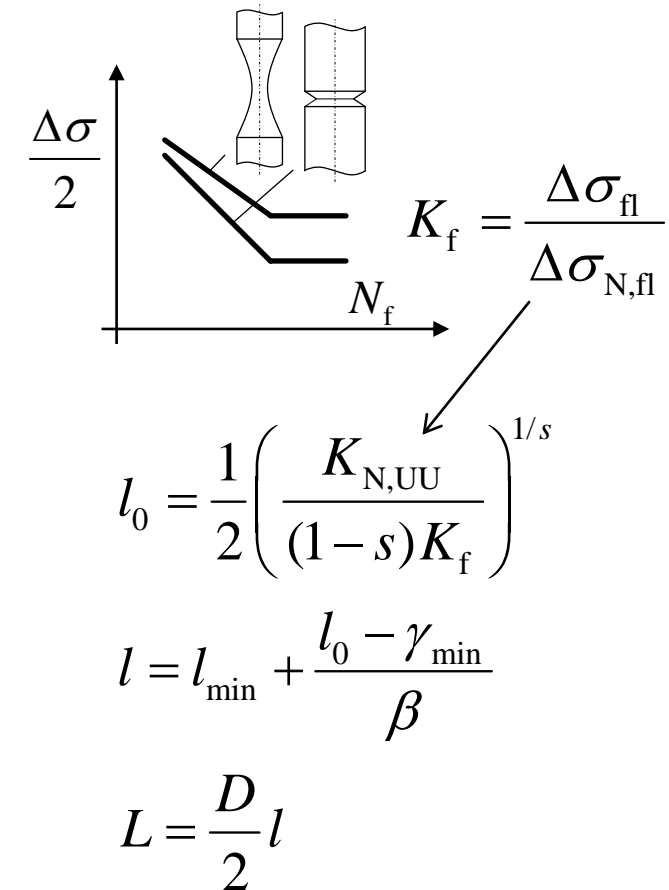
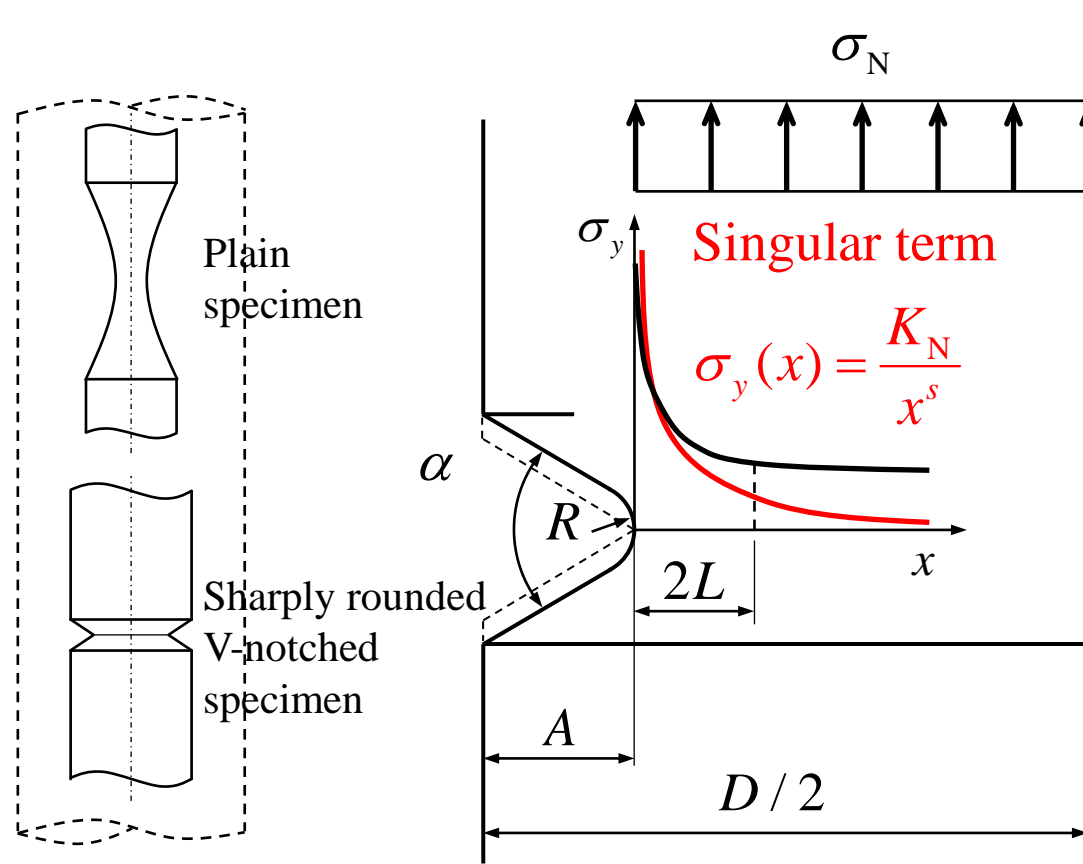

Determination of the fatigue critical distance according to the Line and the Point Methods with rounded V-notched specimen ←

Santus, C., Taylor, D., Benedetti, M.

International Journal of Fatigue, 2018, 106, pp. 208–218



Experimental determination and sensitivity analysis of the fatigue critical distance obtained with rounded V-notched specimens ←

Santus, C., Taylor, D., Benedetti, M.

International Journal of Fatigue, 2018, 113, pp. 113–125



Statistical properties of threshold and notch derived estimations of the critical distance according to the line method of the theory of critical distances

Benedetti, M., Santus, C.

International Journal of Fatigue, 2020, 137, 105656

Critical distance determination, Mode I

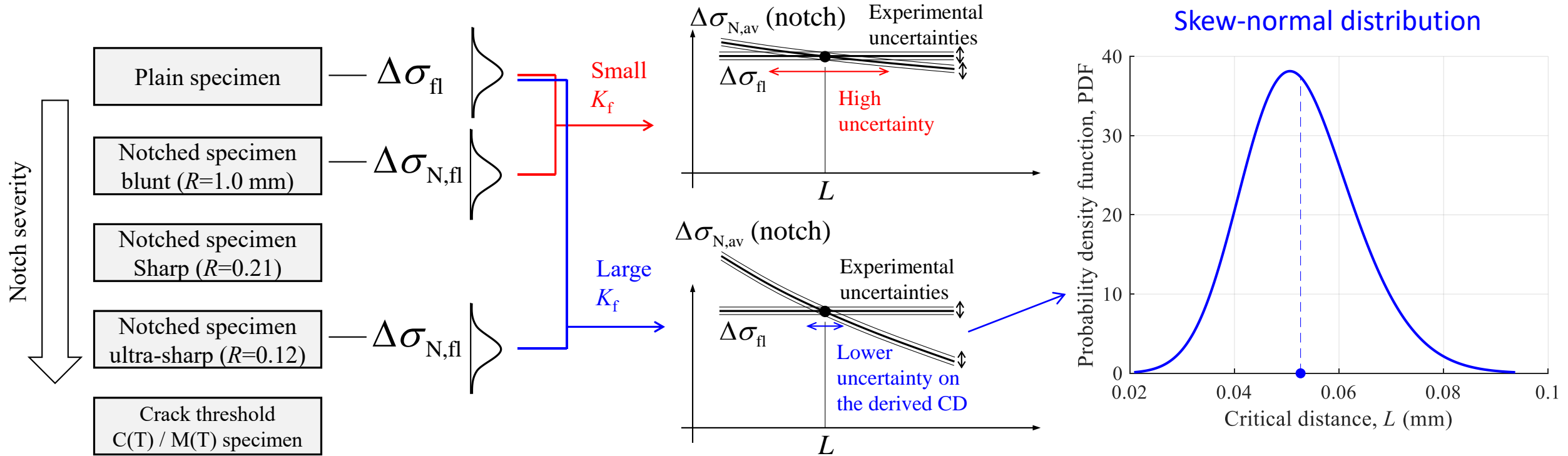

Determination of the fatigue critical distance according to the Line and the Point Methods with rounded V-notched specimen

Santus, C., Taylor, D., Benedetti, M.
International Journal of Fatigue, 2018, 106, pp. 208–218



Experimental determination and sensitivity analysis of the fatigue critical distance obtained with rounded V-notched specimens

Santus, C., Taylor, D., Benedetti, M.
International Journal of Fatigue, 2018, 113, pp. 113–125



Statistical properties of threshold and notch derived estimations of the critical distance according to the line method of the theory of critical distances

Benedetti, M., Santus, C.
International Journal of Fatigue, 2020, 137, 105656

Critical distance determination, Mode III, or “Torsional”

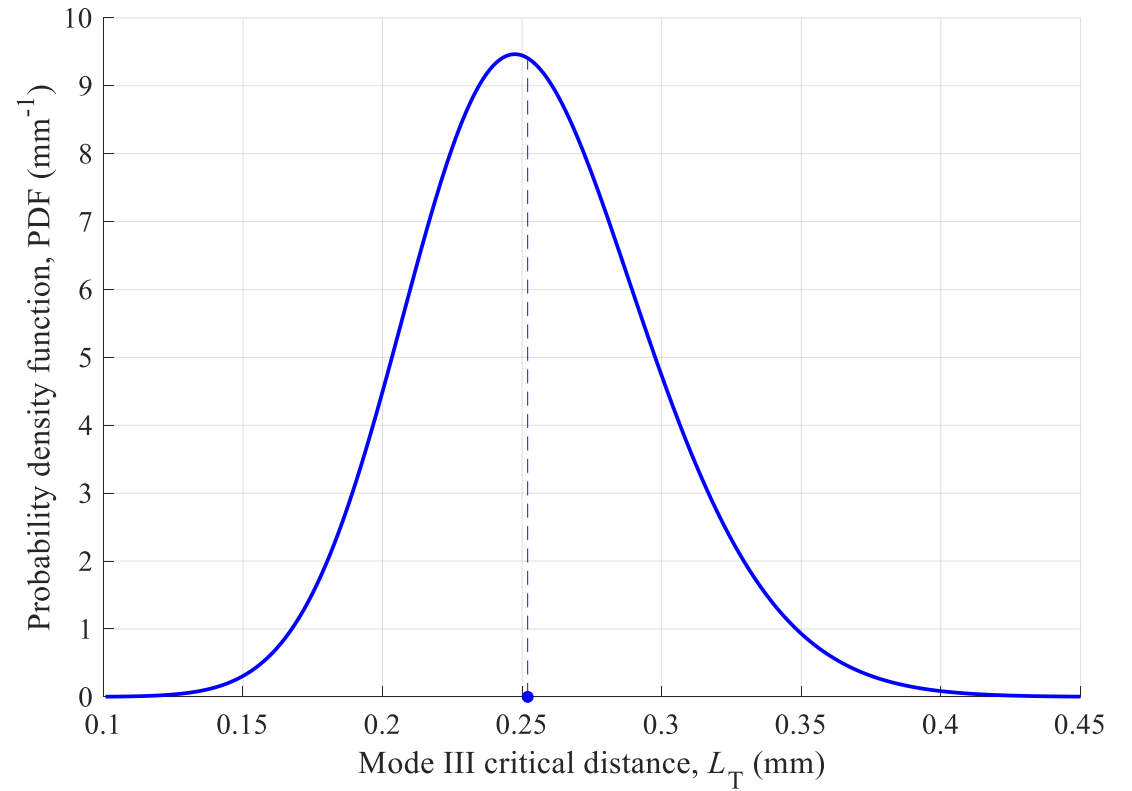
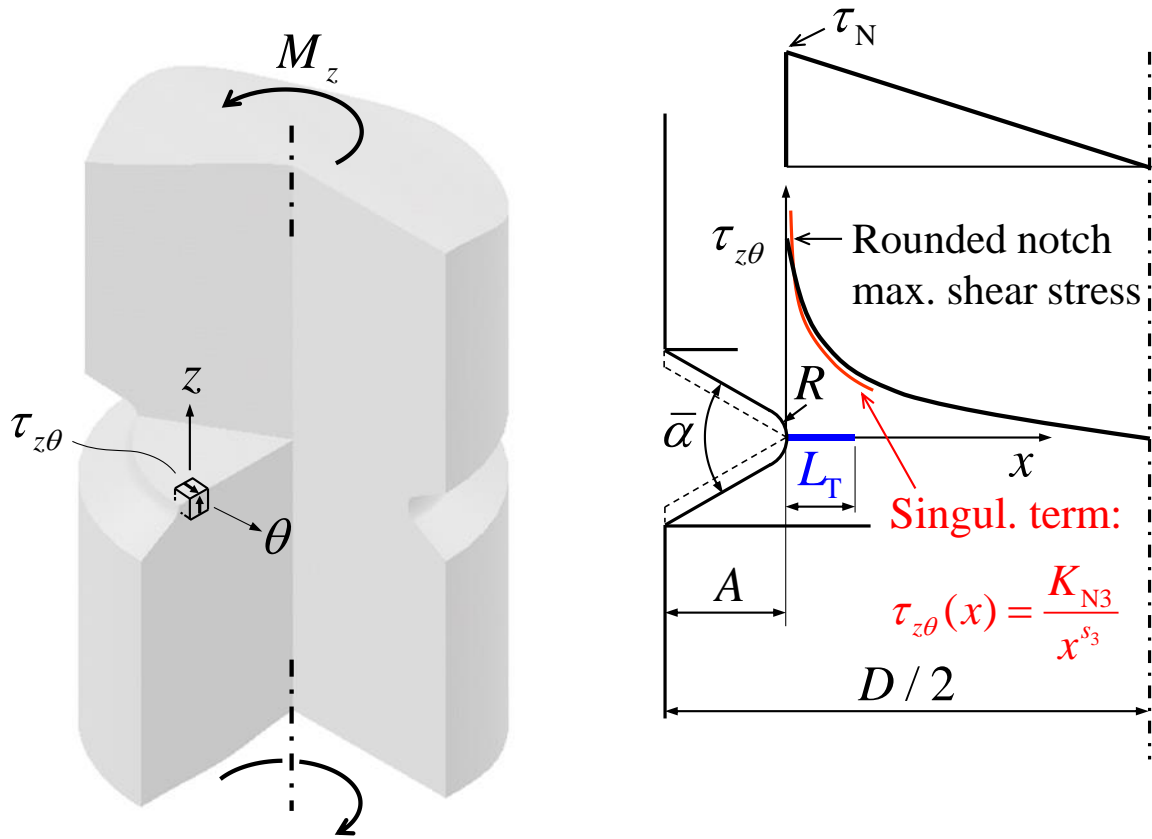

Mode III critical distance determination with optimized V-notched specimen under torsional fatigue and size effects on the inverse search probability distribution

Santus, C., Berto, F., Pedranz, M., Benedetti, M.
International Journal of Fatigue, 2021, 151, 106351



Specimens investigated, Mode I

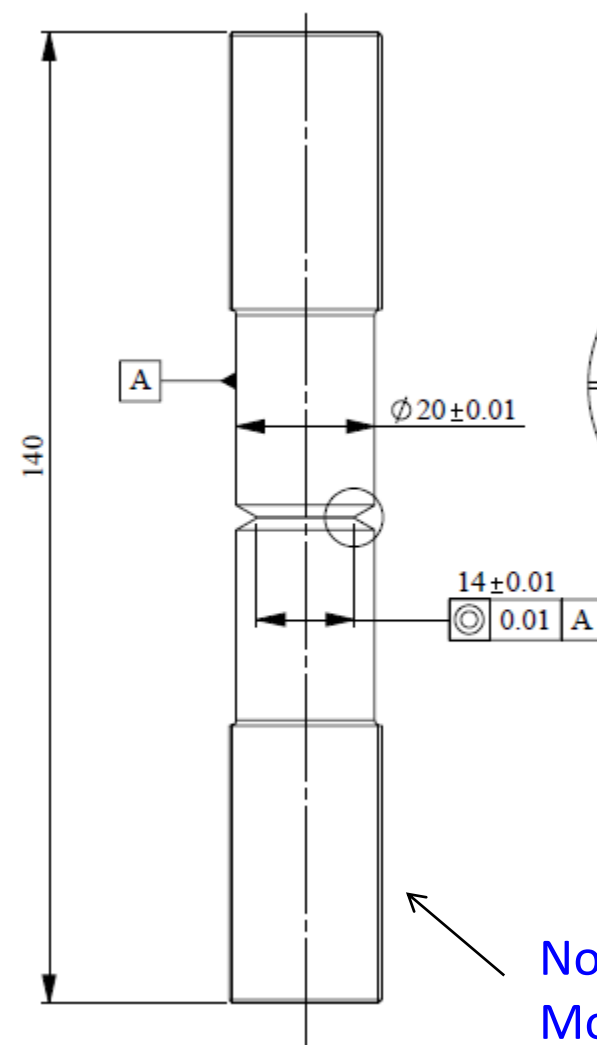
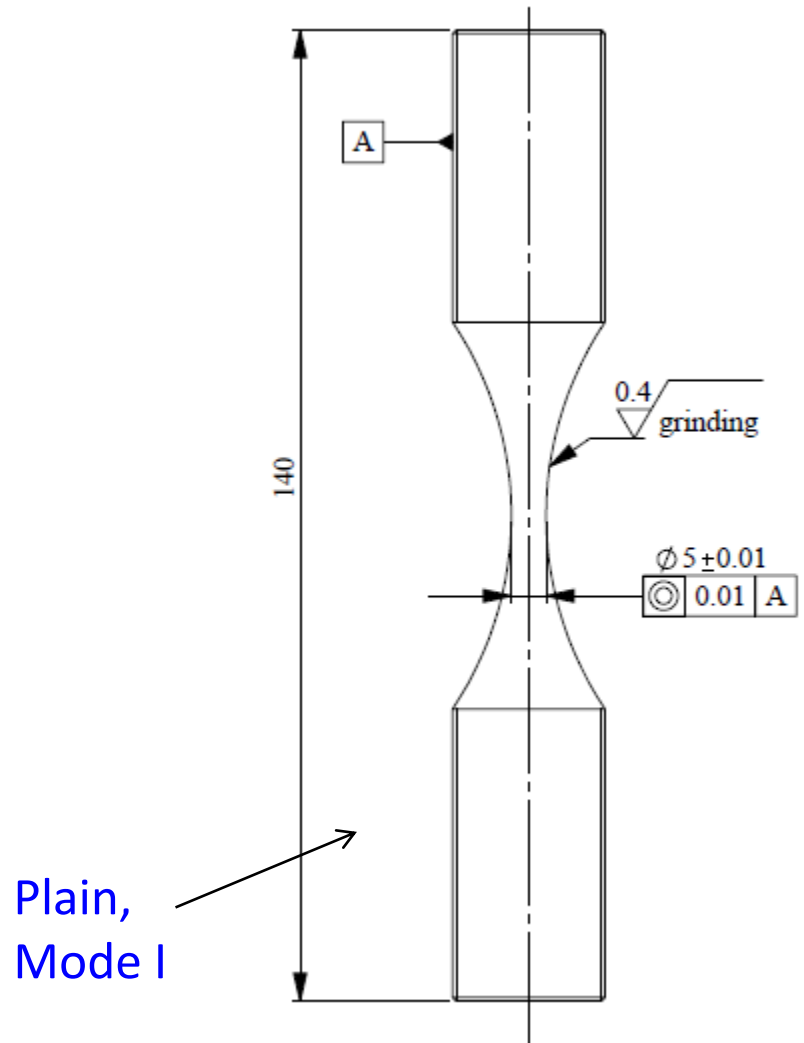

Recommended specimen notch angle and radius

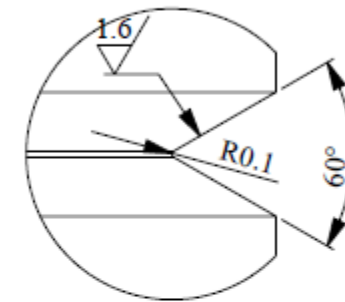

Experimentally detected actual radius

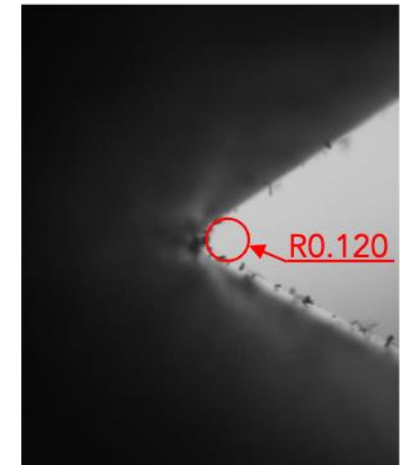

Specimens investigated, Mode III

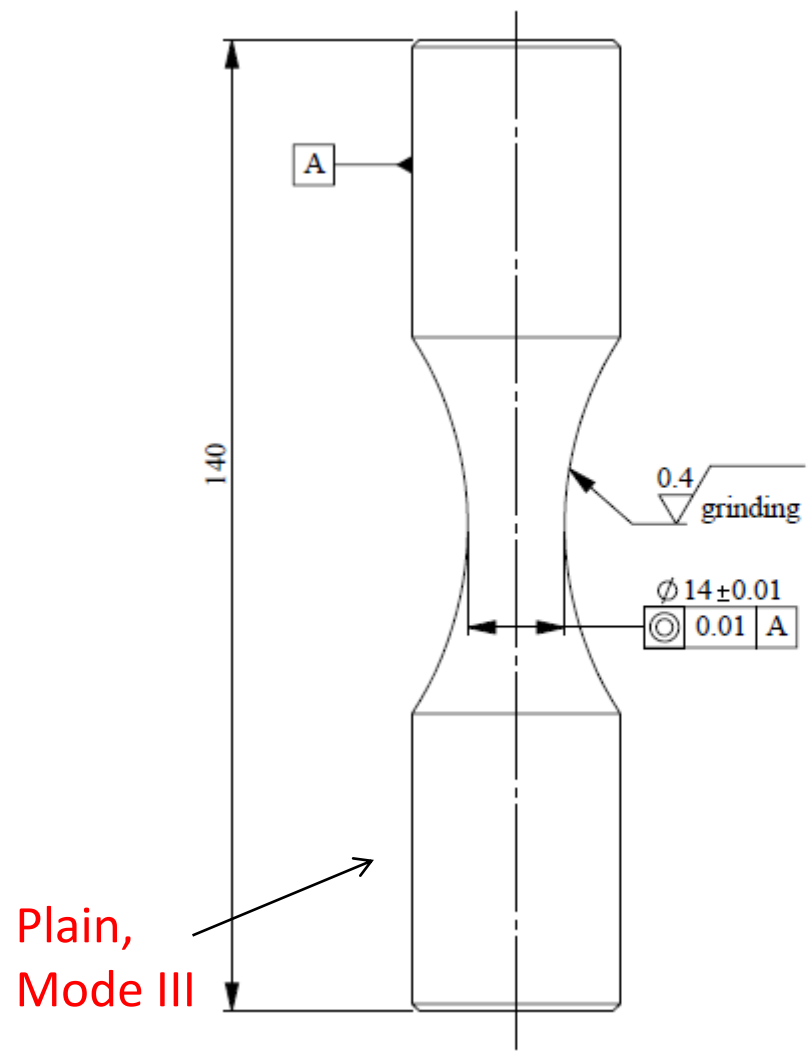

Plain,
Mode III

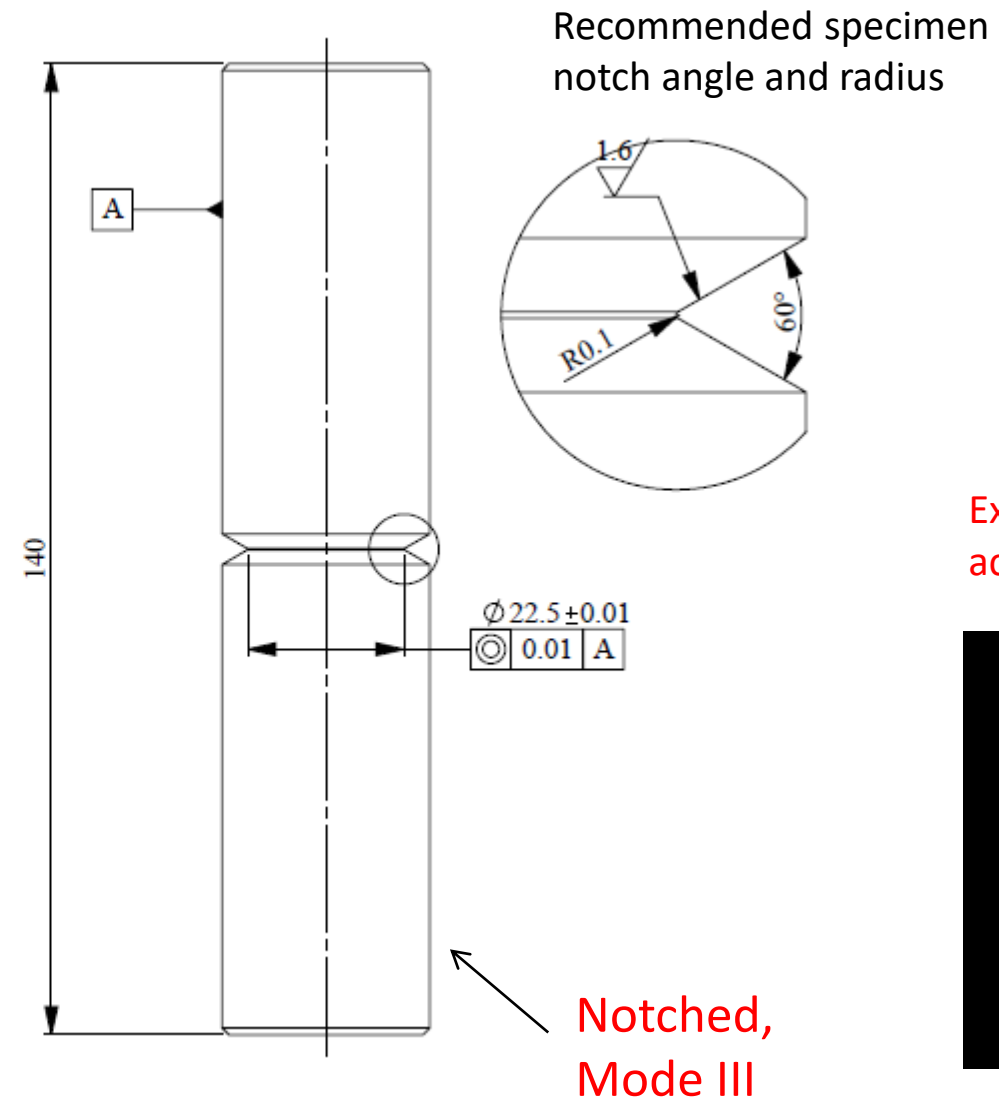

Notched,
Mode III

Experimentally detected actual radius

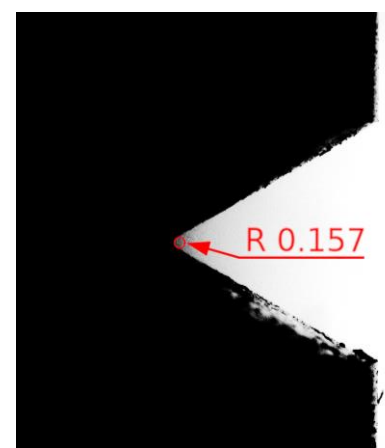

Experimental results, steel 42CrMo4+QT, Mode I (load ratio $R = -1$)

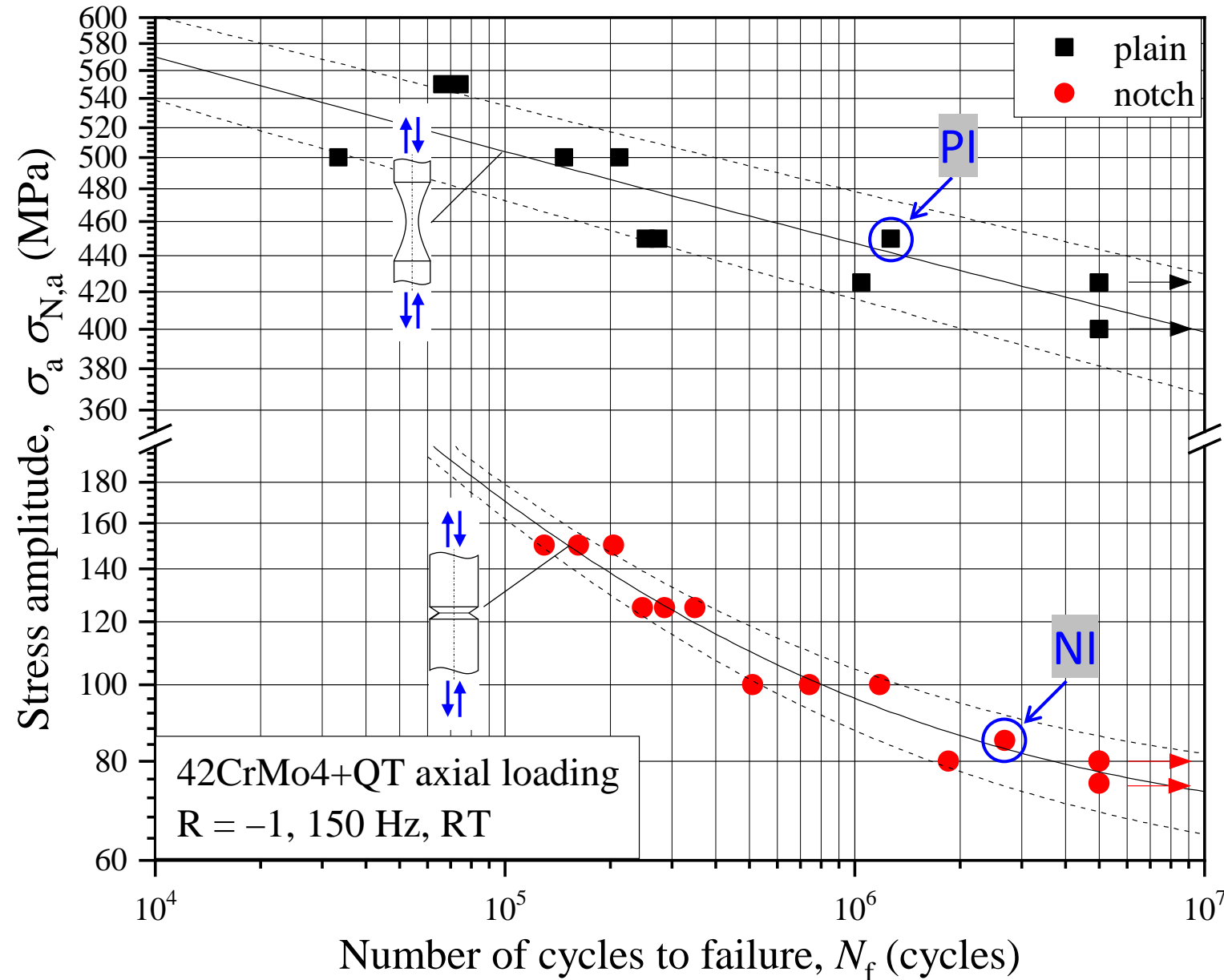

○
 Investigated
 fracture
 specimens

Obtained critical distance
 prediction, Mode I:

$$\sigma_{fl} = 412 \text{ MPa}$$

$$L = 0.027 \text{ mm}$$

$$\delta(L) = 0.012 \text{ mm}$$

Experimental results, steel 42CrMo4+QT, Mode III (load ratio $R = -1$)

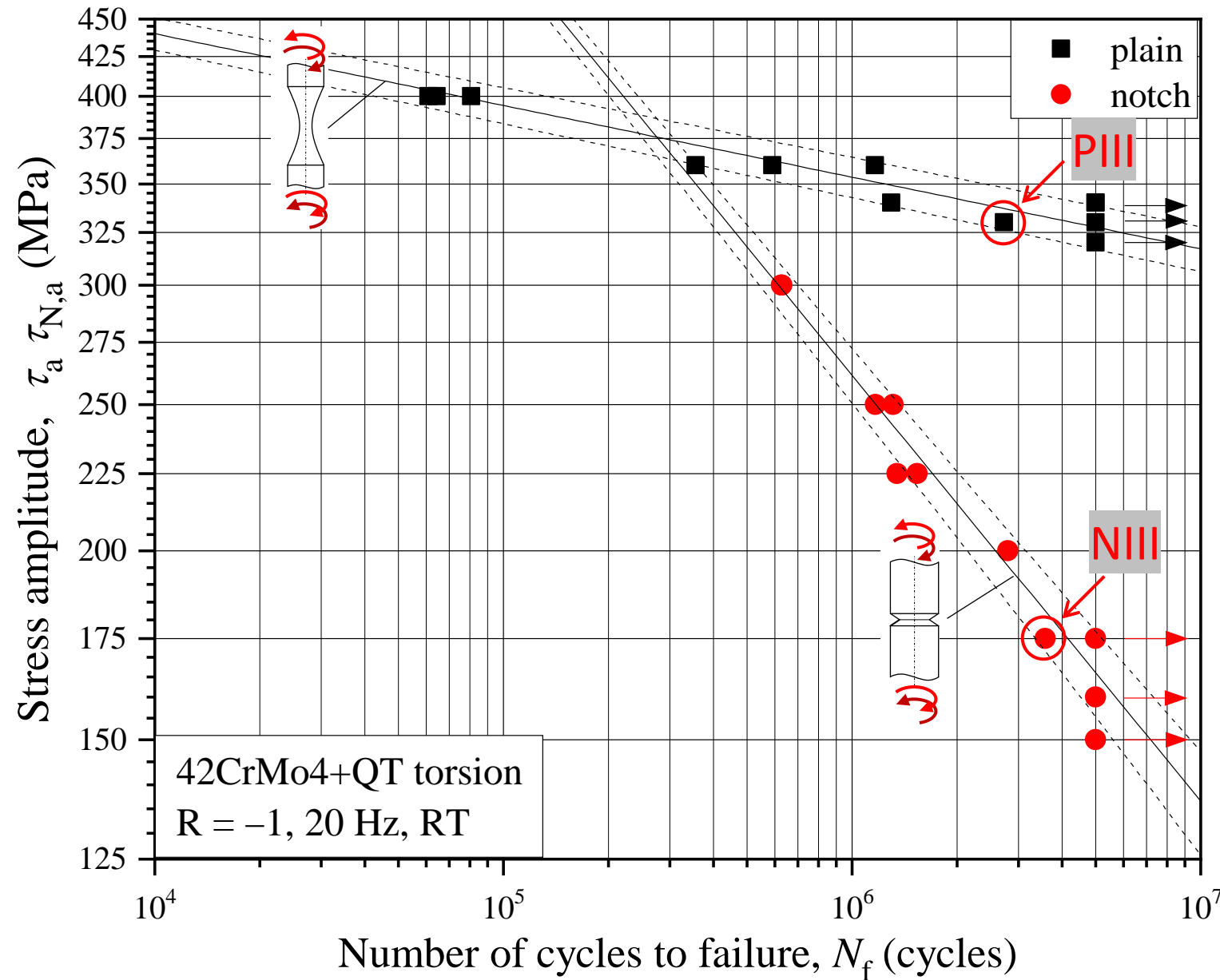

Investigated fracture specimens

Obtained critical distance prediction, Mode III:

$$\tau_{fl} = 316 \text{ MPa}$$

$$L_T = 0.252 \text{ mm}$$

$$\delta(L_T) = 0.043 \text{ mm}$$

Experimental results, alum. alloy 7075-T6, Mode I / Mode III (R = -1)

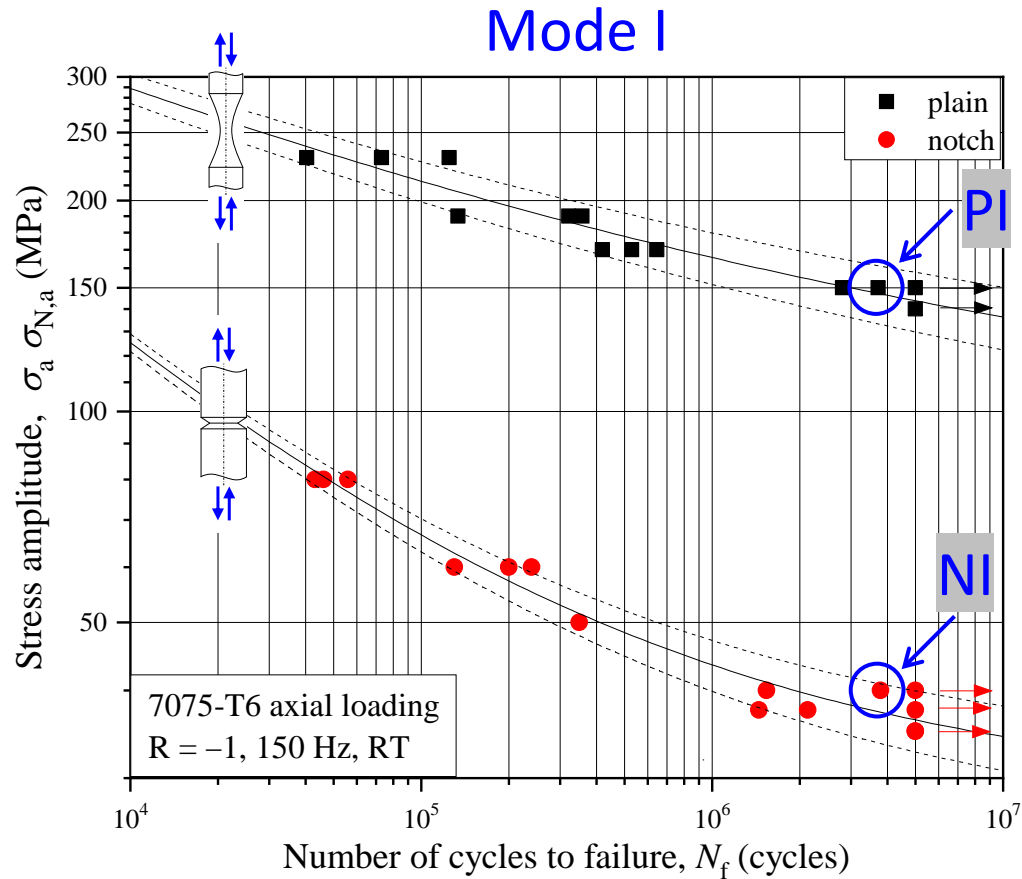

$$\sigma_{fl} = 144 \text{ MPa}$$

$$L = 0.070 \text{ mm}$$

$$\delta(L) = 0.022 \text{ mm}$$

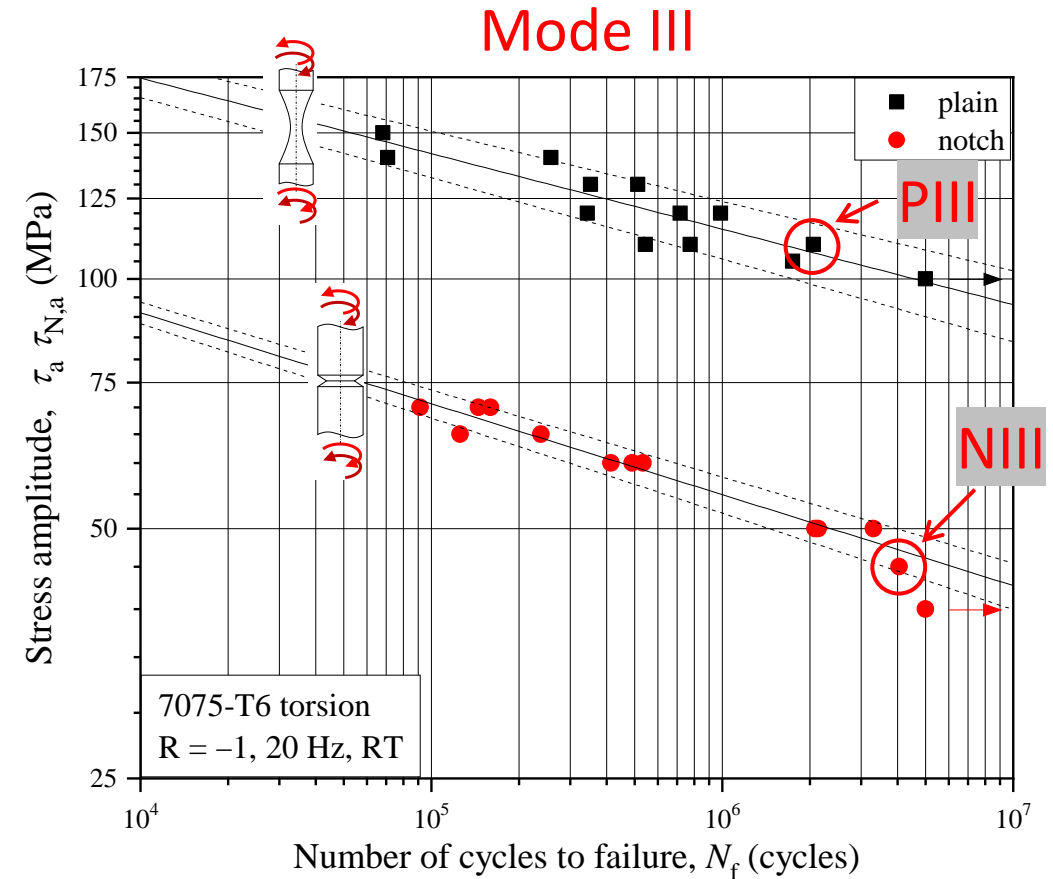

$$\tau_{fl} = 99 \text{ MPa}$$

$$L_T = 0.201 \text{ mm}$$

$$\delta(L_T) = 0.053 \text{ mm}$$

Steel 42CrMo4+QT, Mode I, fracture surface investigation

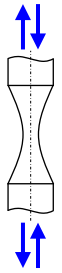

PI = Plain mode I

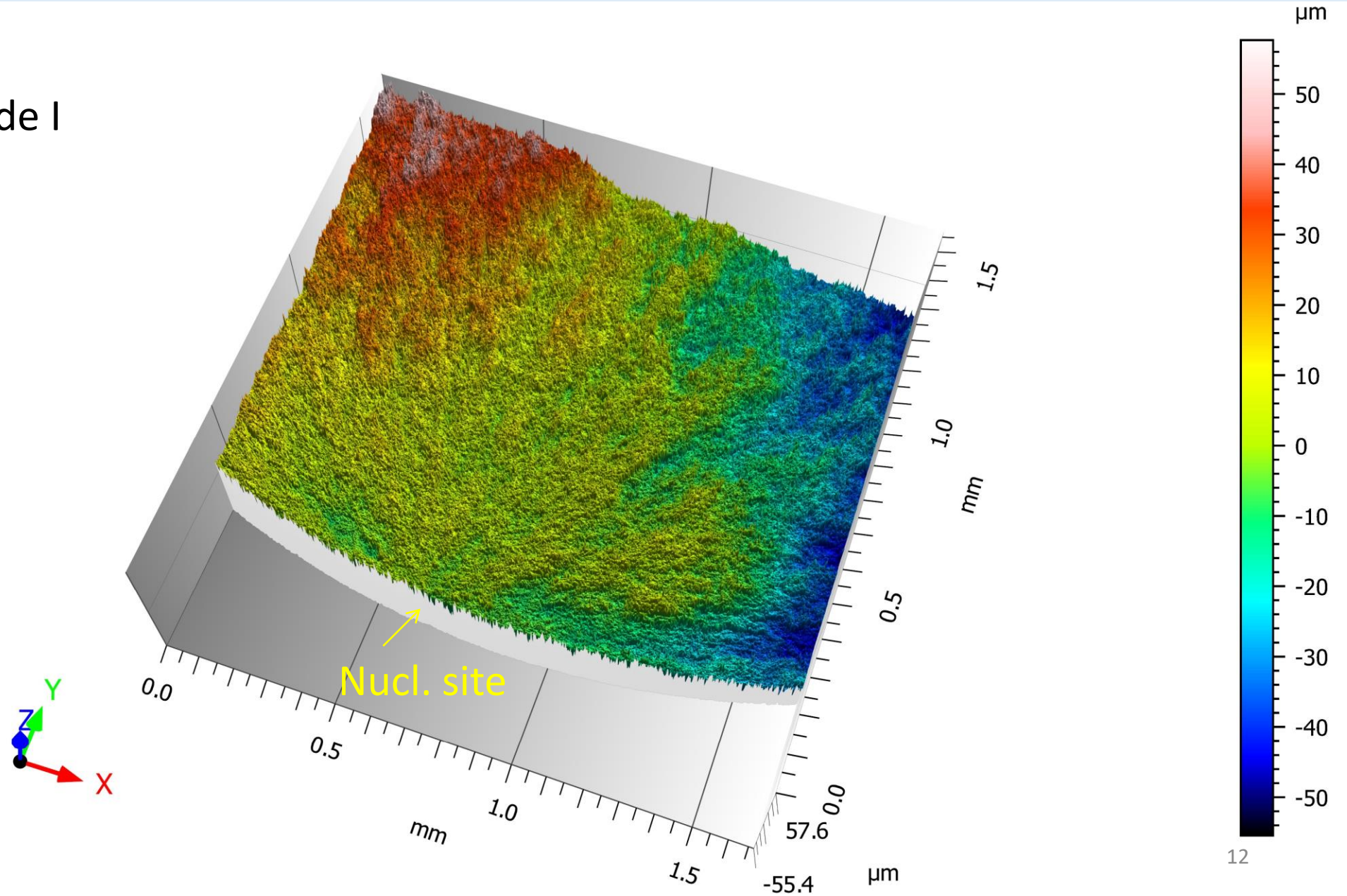
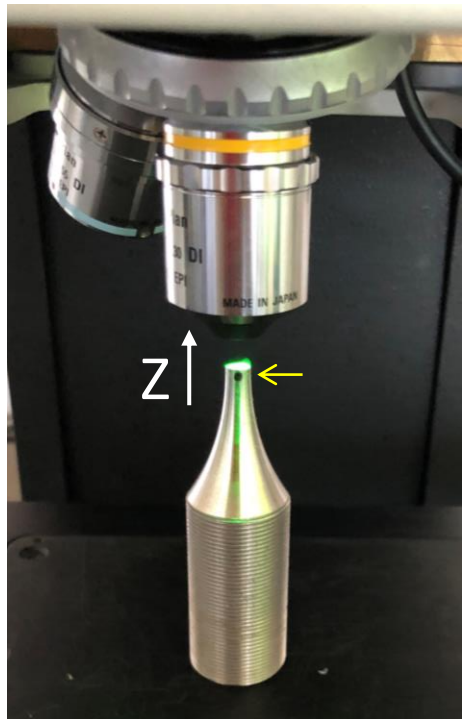

Steel 42CrMo4+QT, Mode I, fracture surface investigation

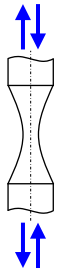

PI = Plain mode I

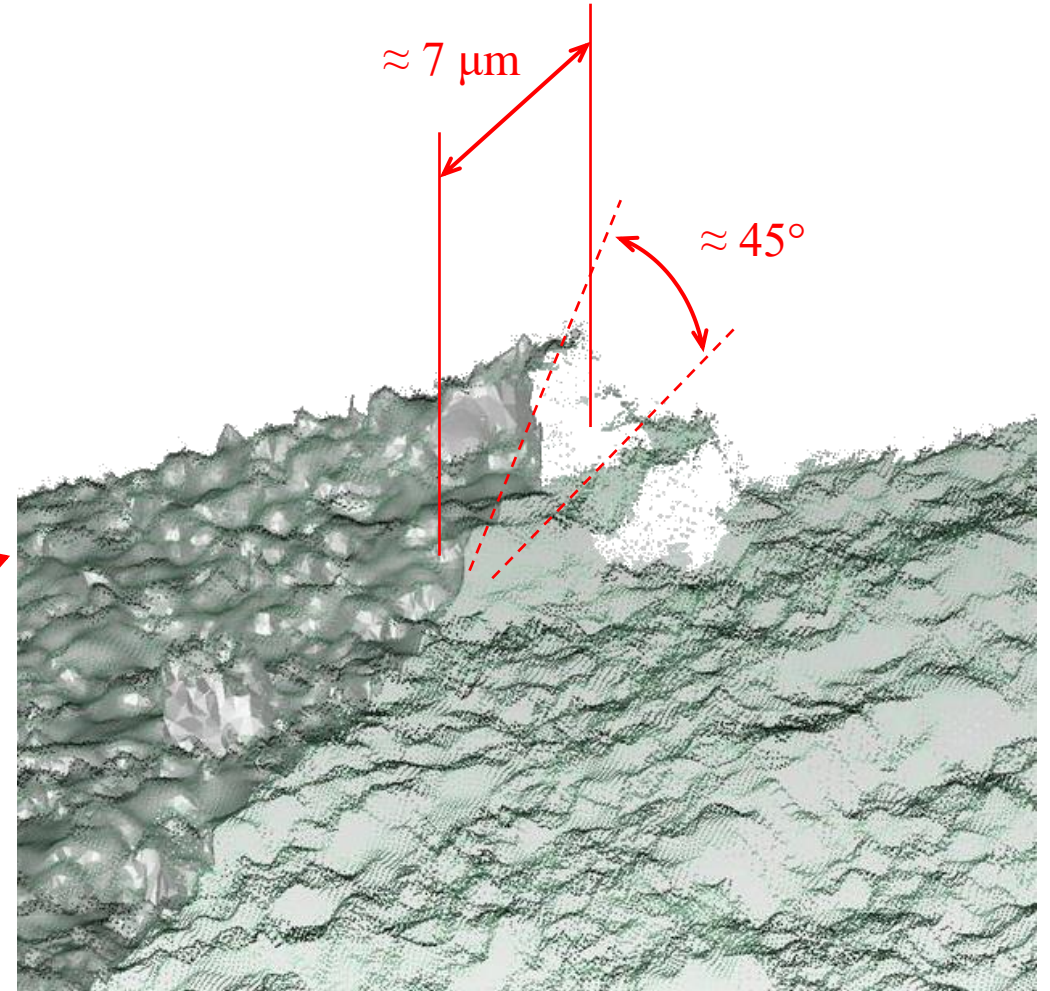
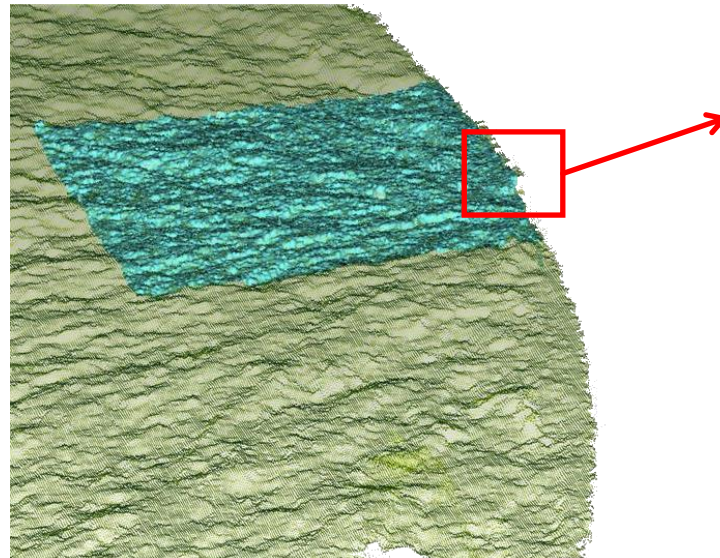
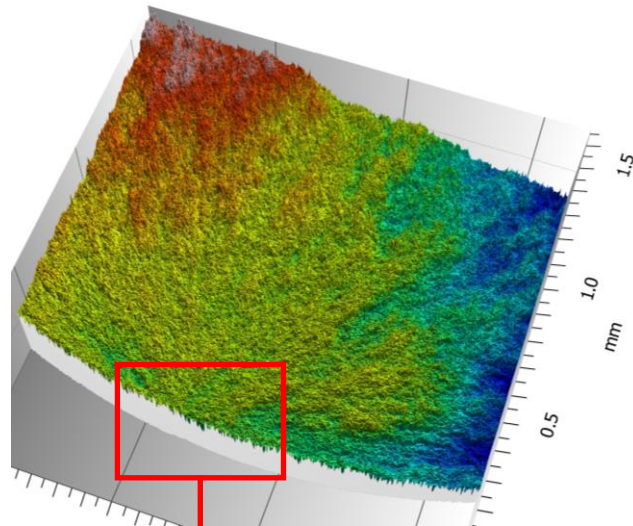

Steel 42CrMo4+QT, Mode I, fracture surface investigation

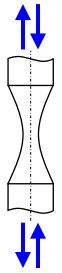

PI = Plain mode I

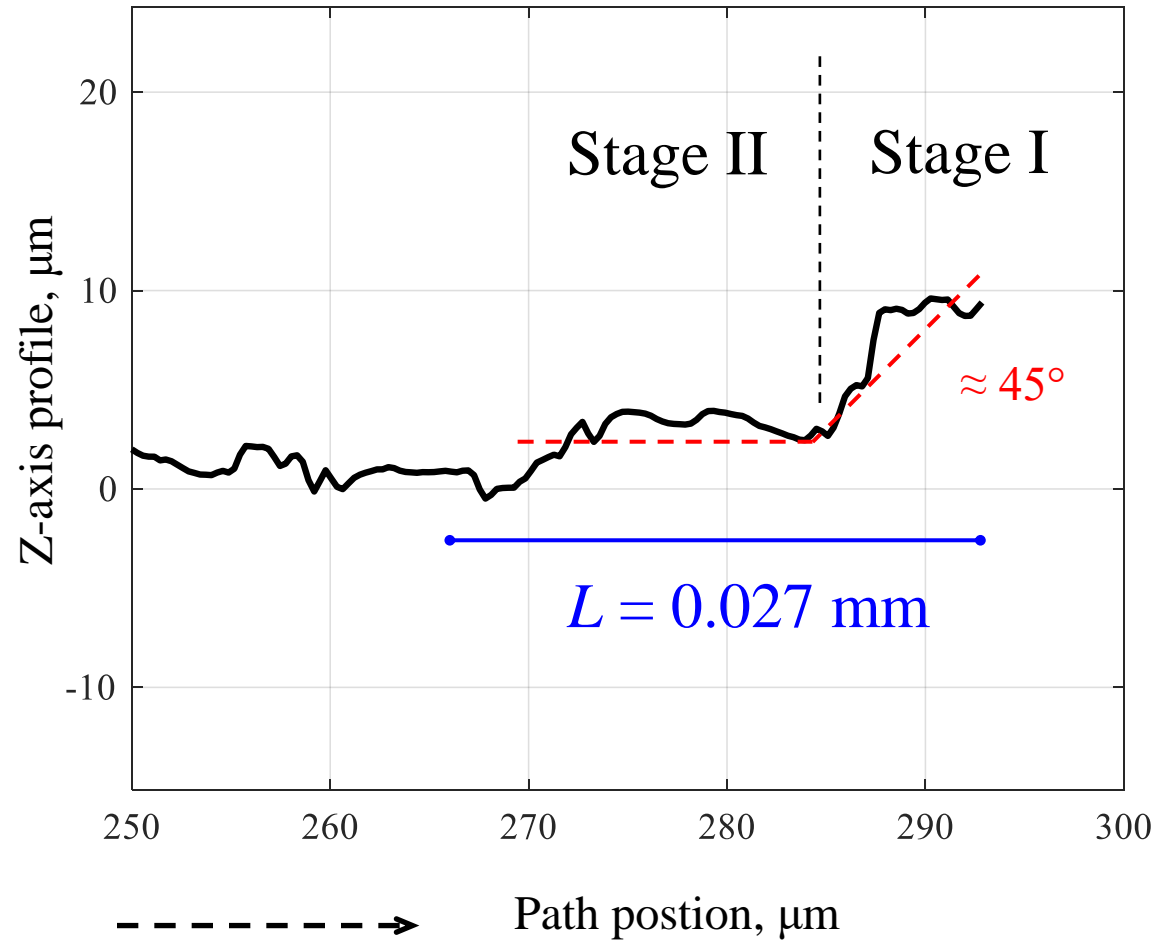
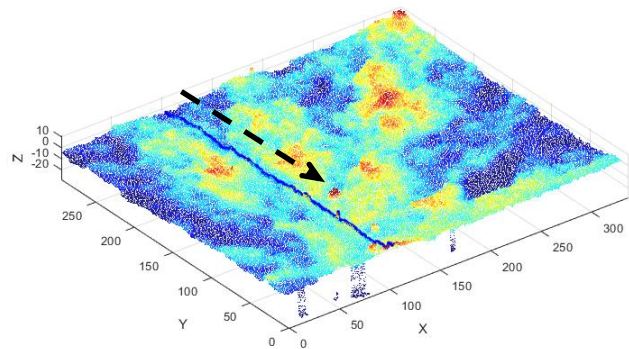
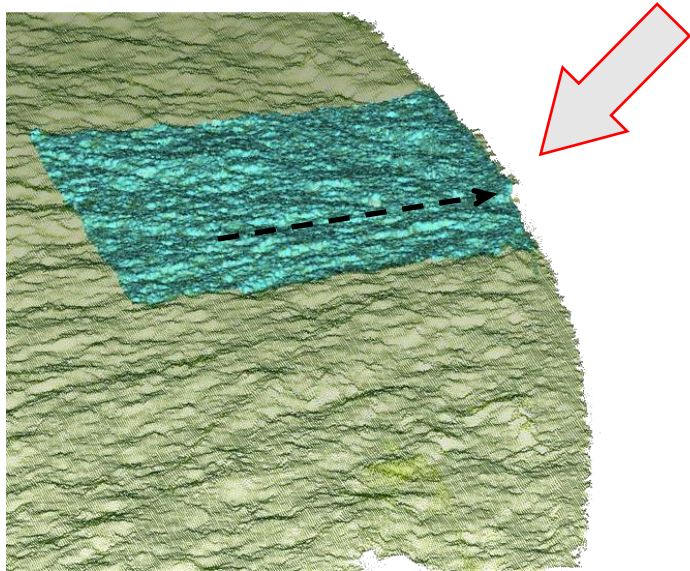

Steel 42CrMo4+QT, Mode I, fracture surface investigation

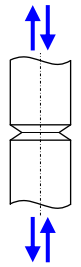

NI = Notched mode I

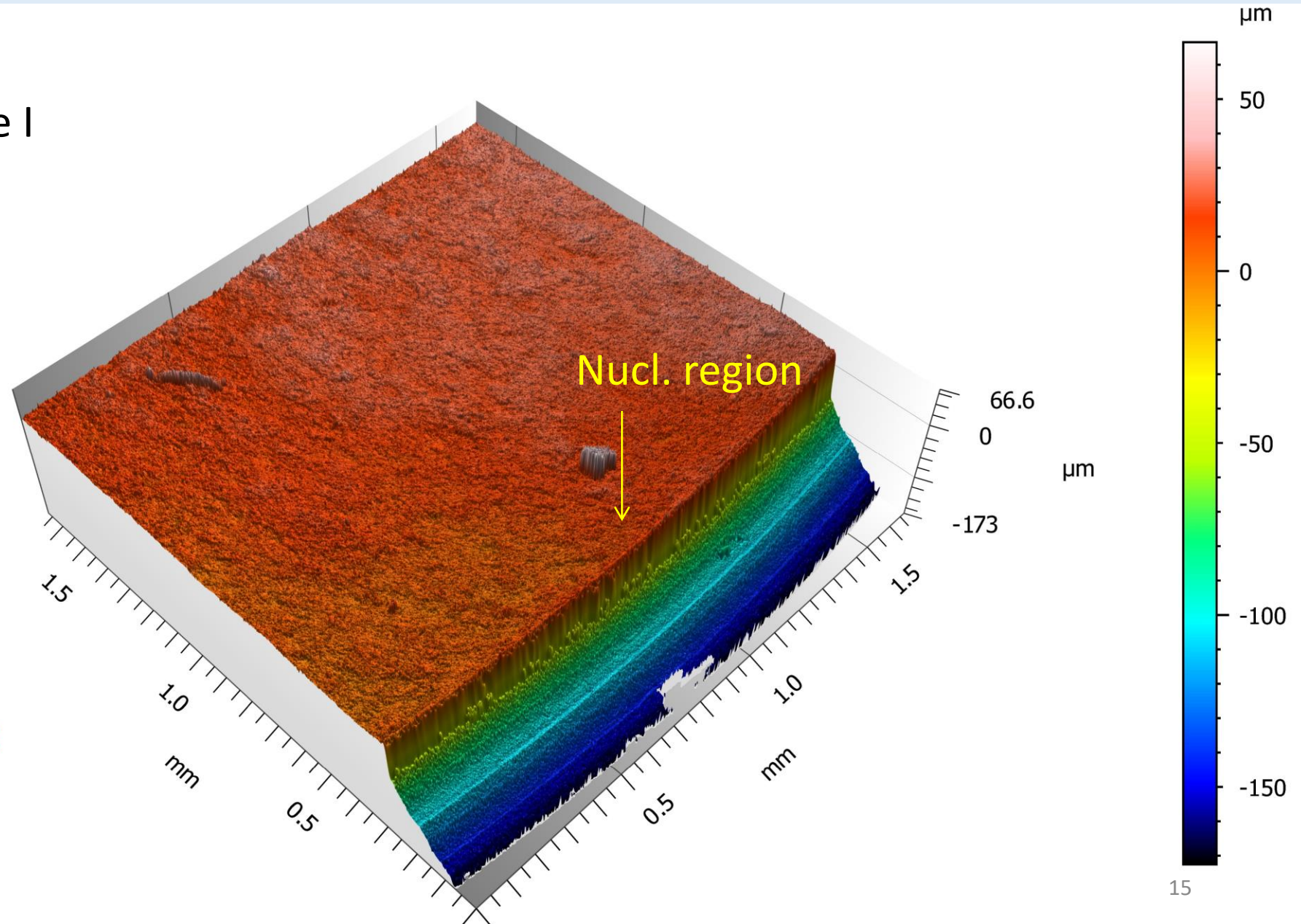
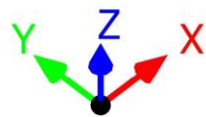
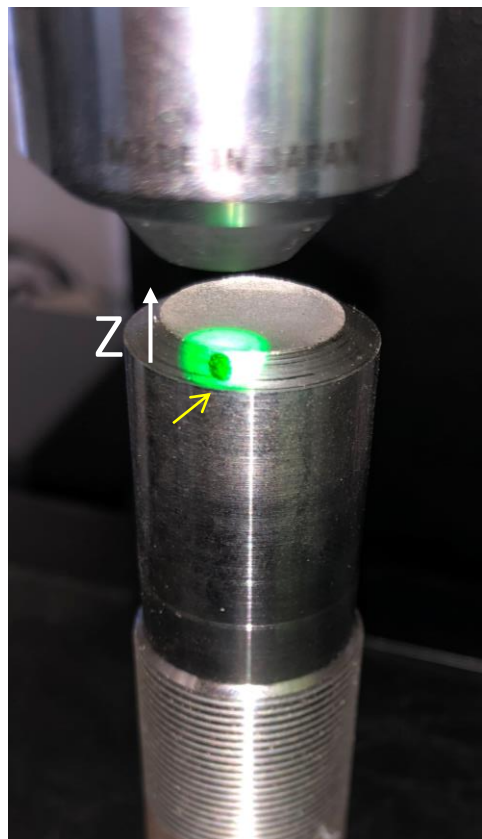

Steel 42CrMo4+QT, Mode I, fracture surface investigation

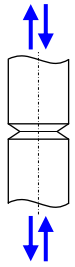

NI = Notched mode I

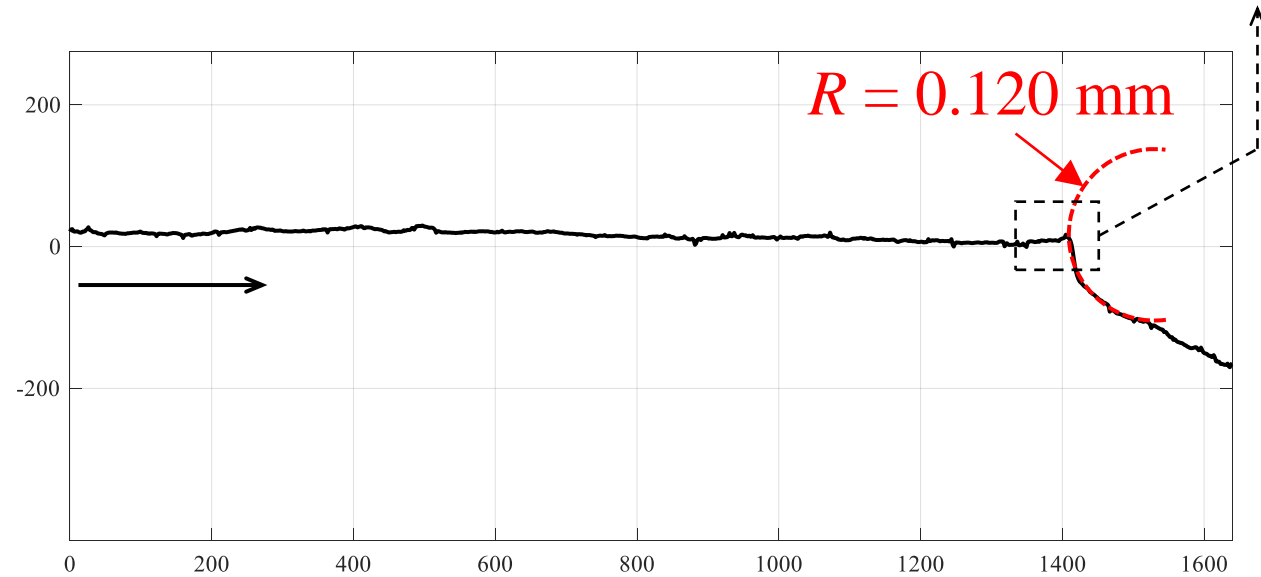
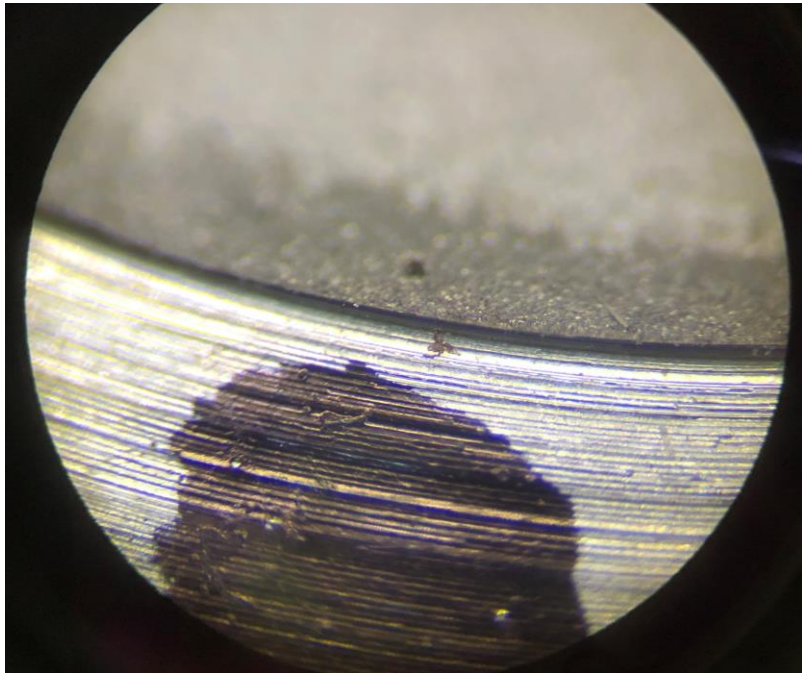
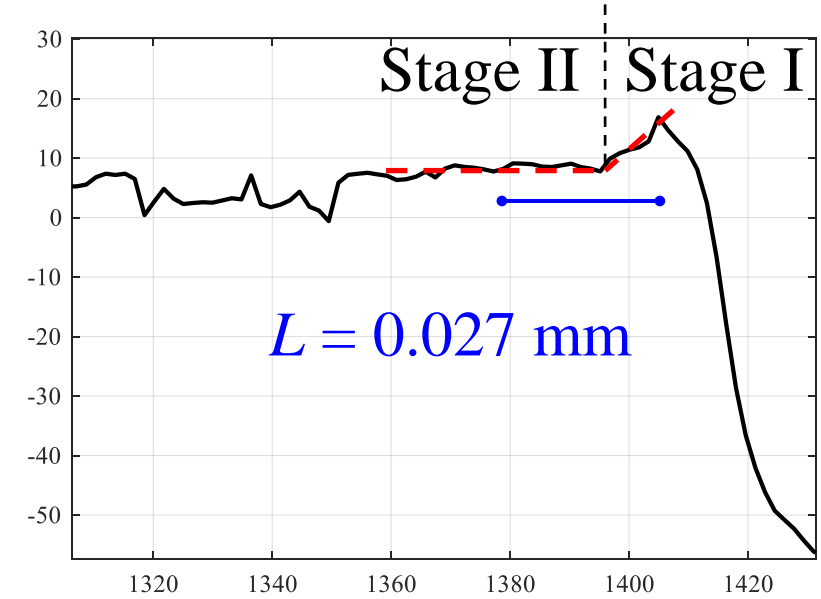
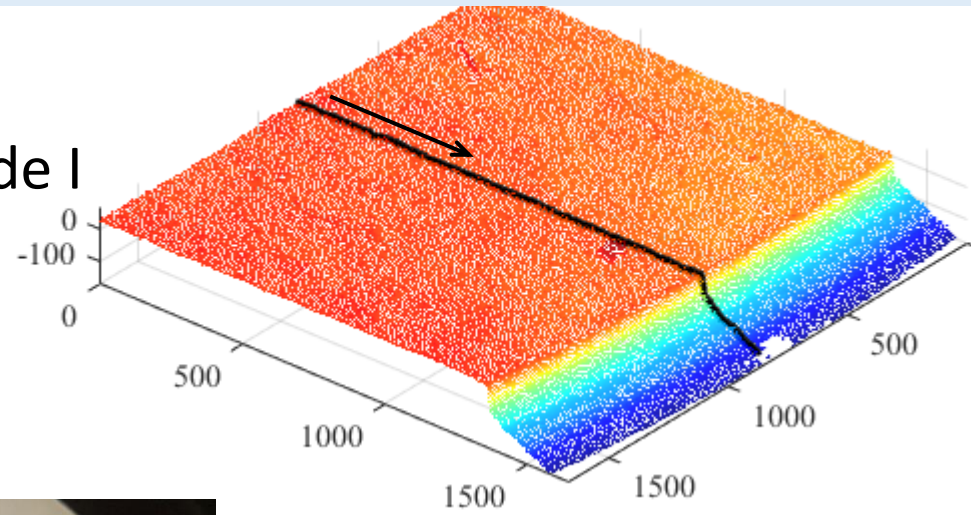

Steel 42CrMo4+QT, Mode III, fracture surface investigation

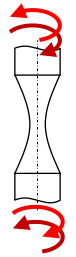

PIII = Plain mode III

Initiation
(semi-elliptical crack)

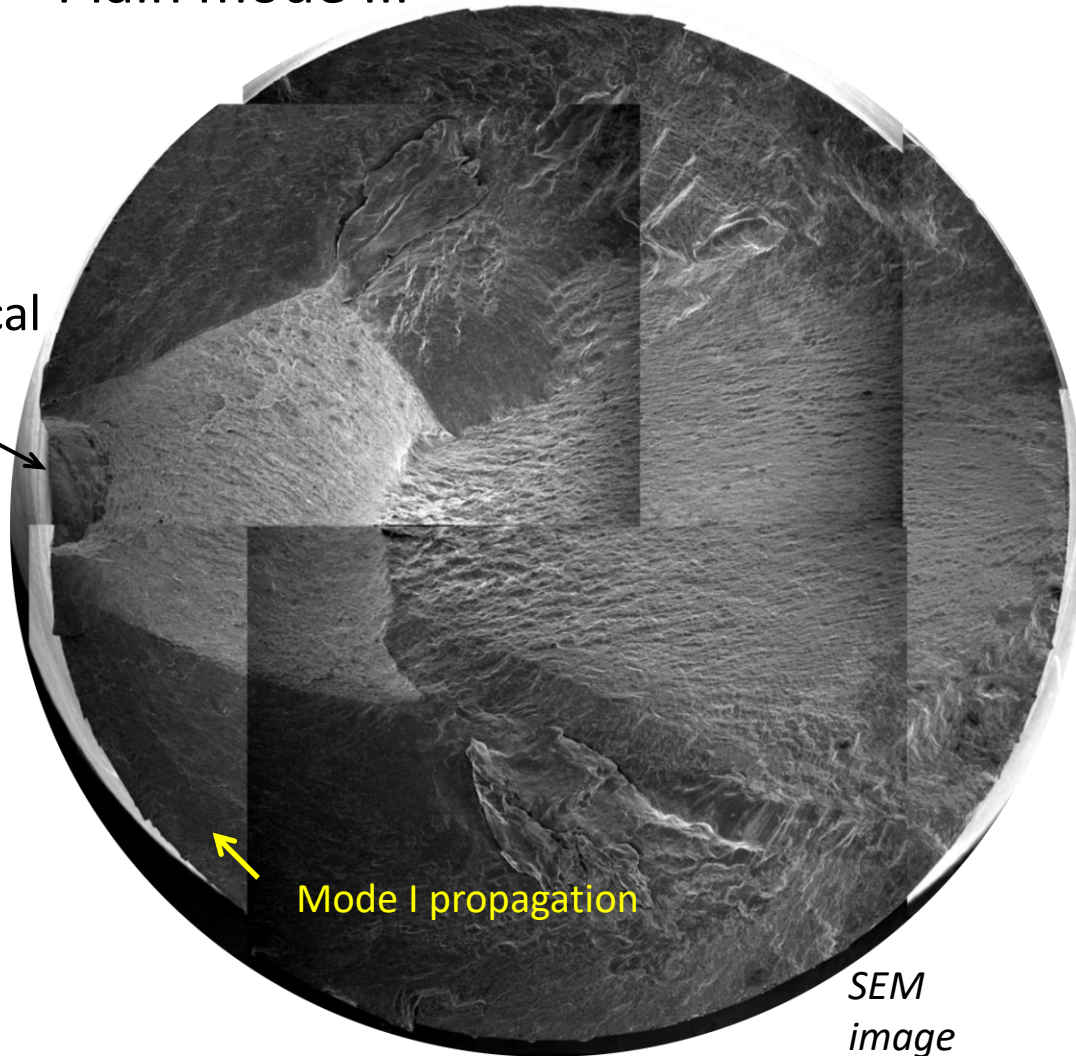

SEM
image

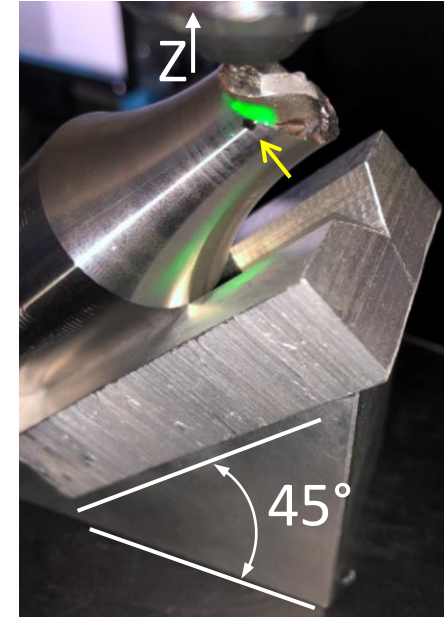

After
reorientation

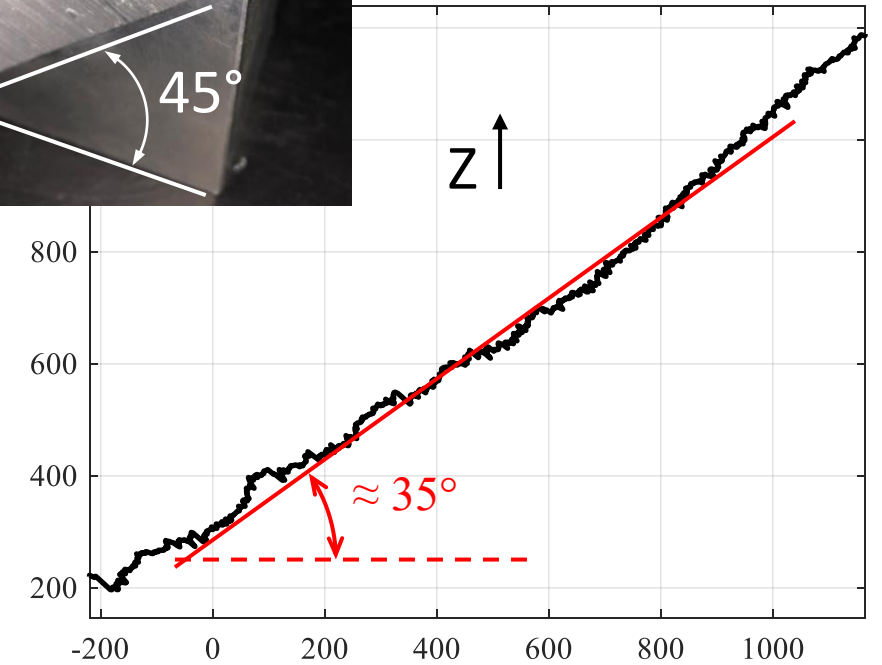

Steel 42CrMo4+QT, Mode III, fracture surface investigation

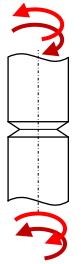

PIII = Notched mode III

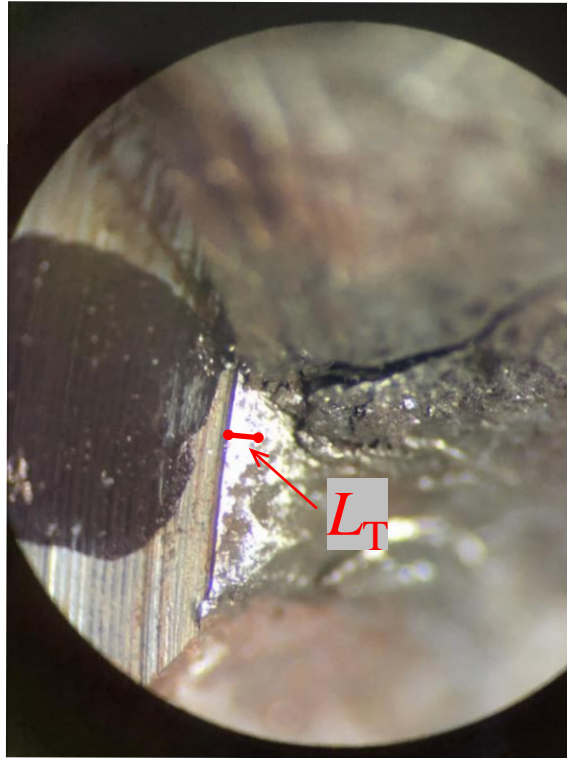
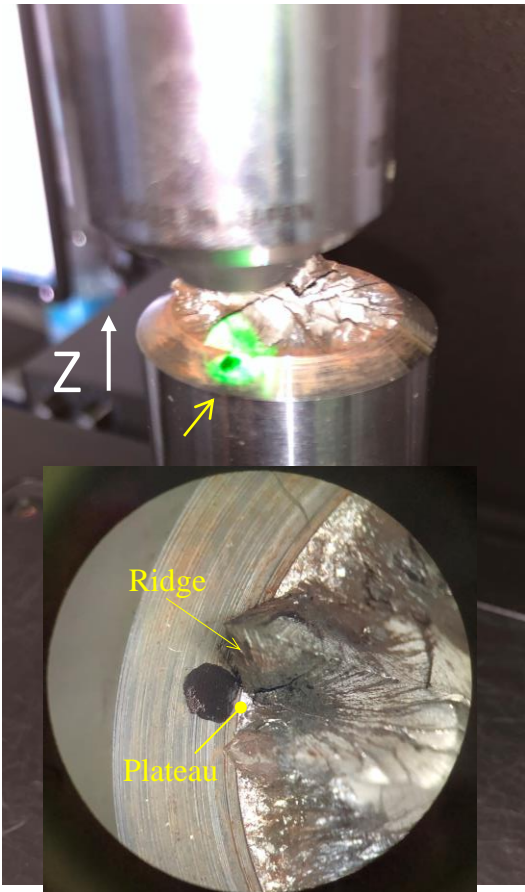

Stereo microscope

Evident Factory-Roof fracture surface

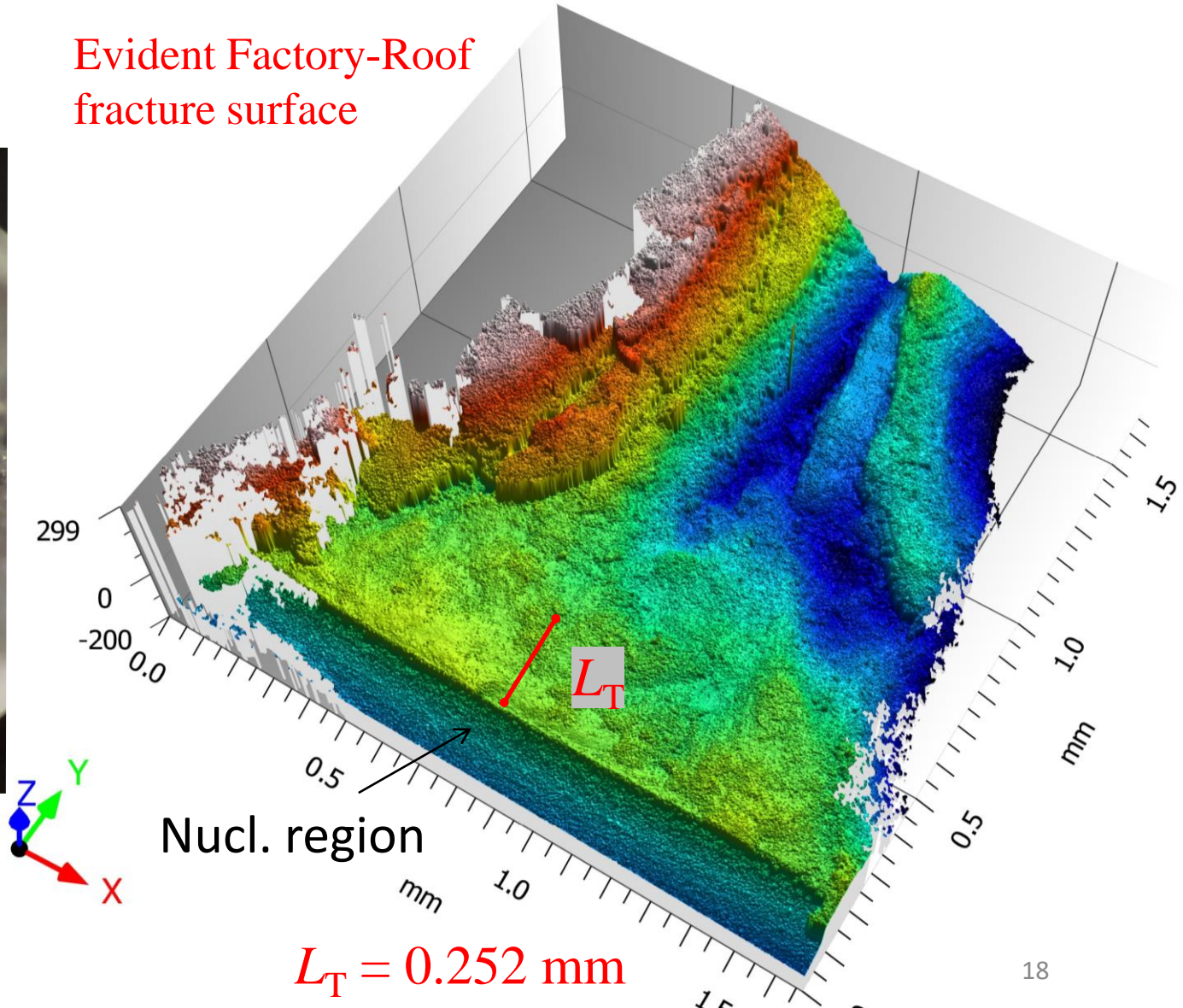

Steel 42CrMo4+QT, Mode III, fracture surface investigation

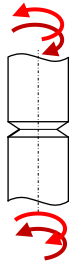

PIII = Notched mode III

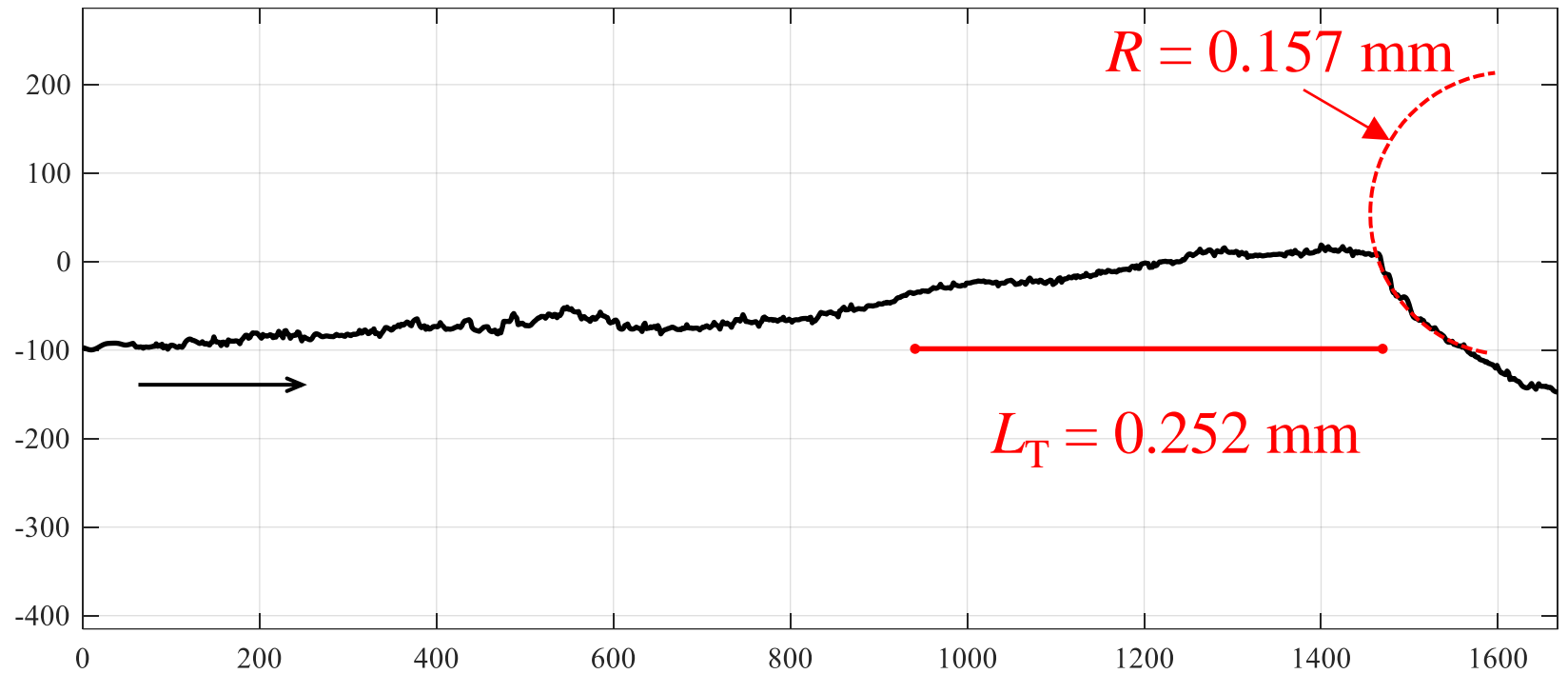
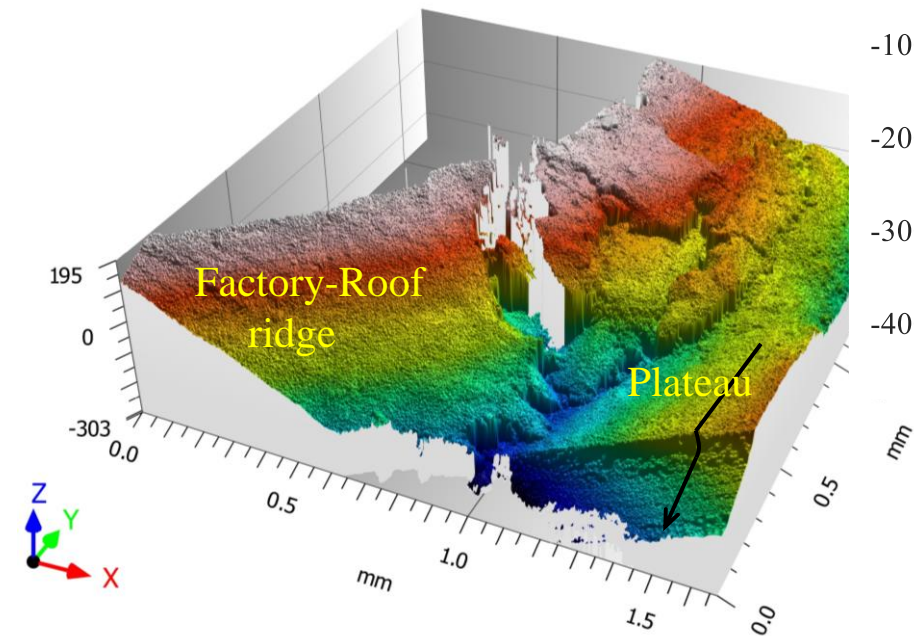

Alum. alloy 7075-T6, Mode I, fracture surface investigation

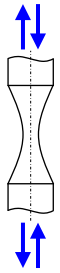

PI = Plain mode I

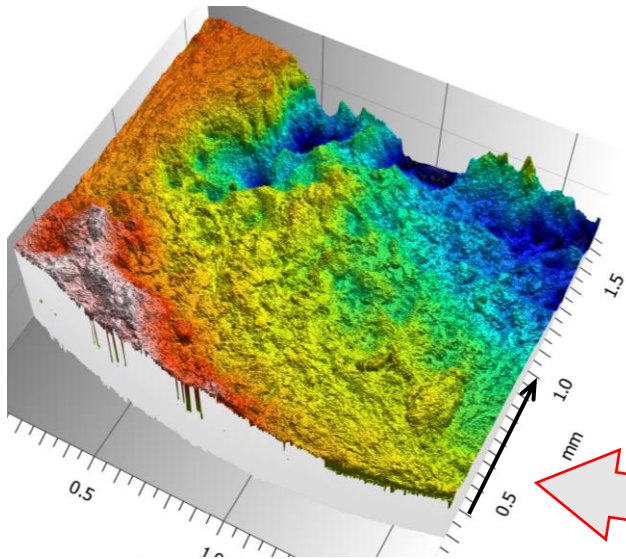
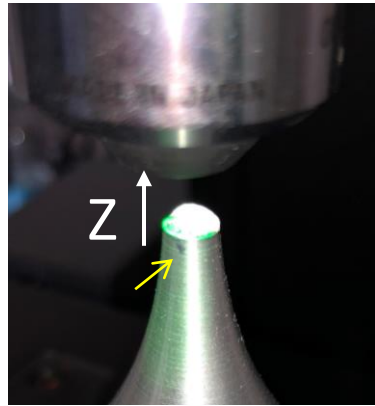

Al. Alloy, more irregular fracture surface:
Not evident Stage I to Stage II transition

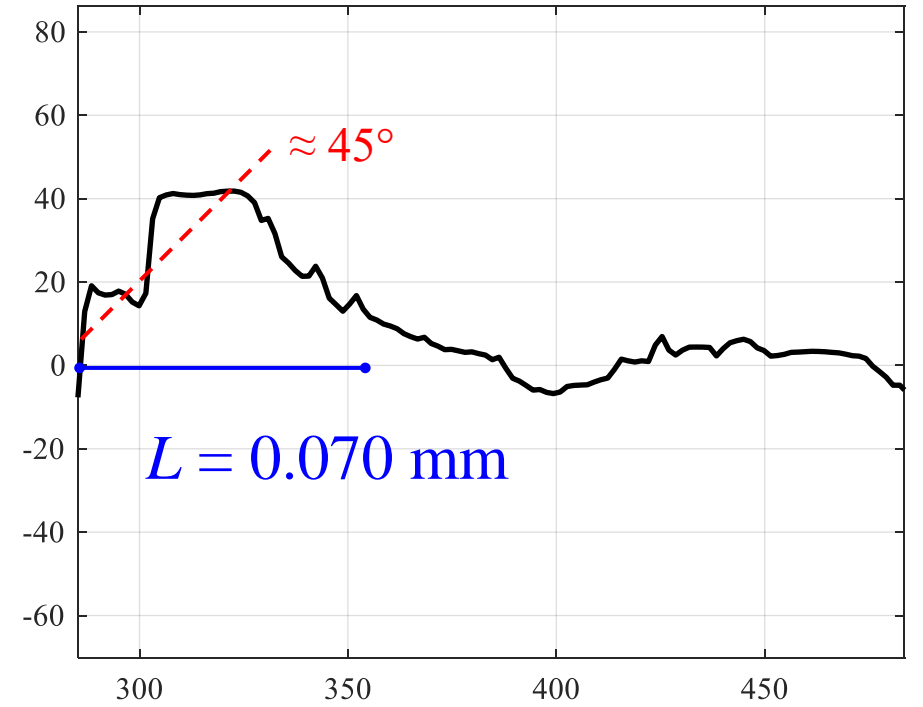
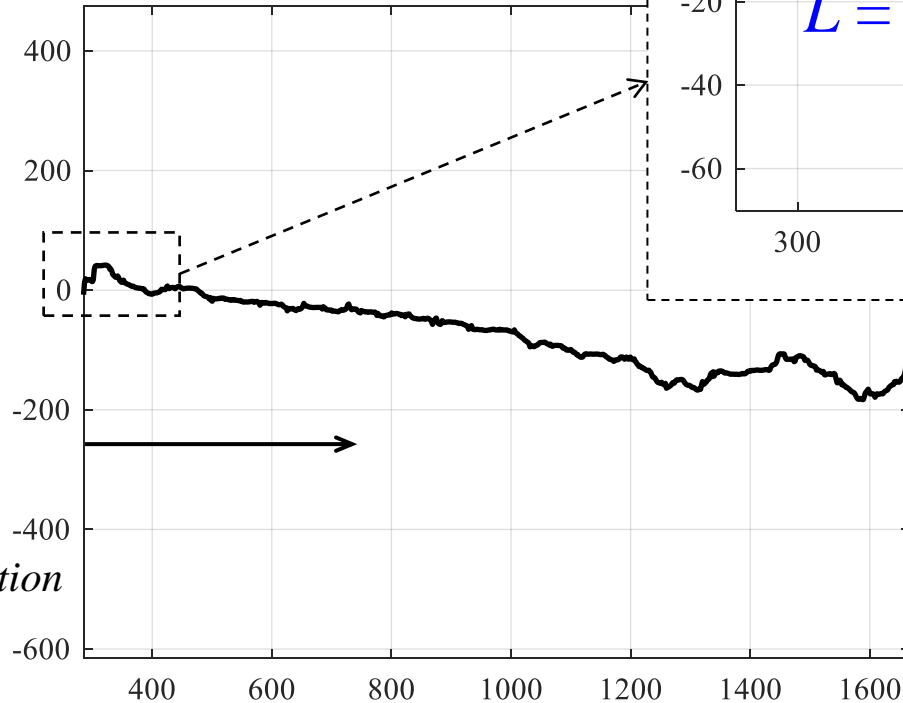

Alum. alloy 7075-T6, Mode I, fracture surface investigation

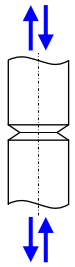

NI = Notched mode I

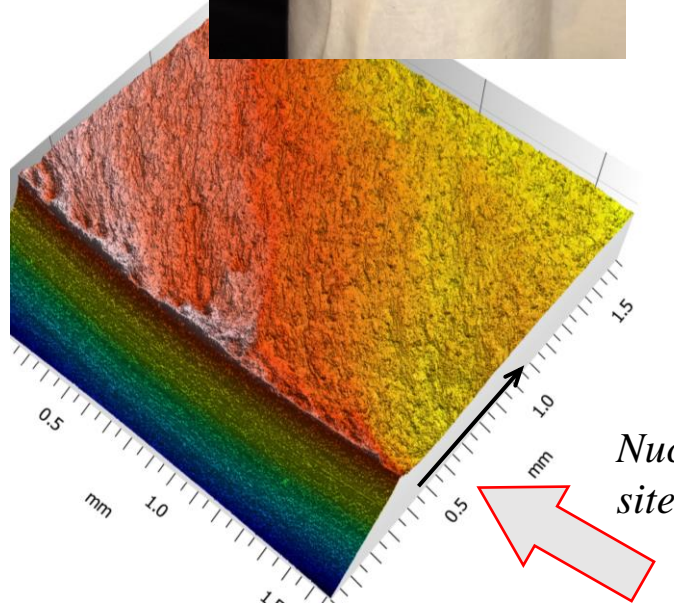
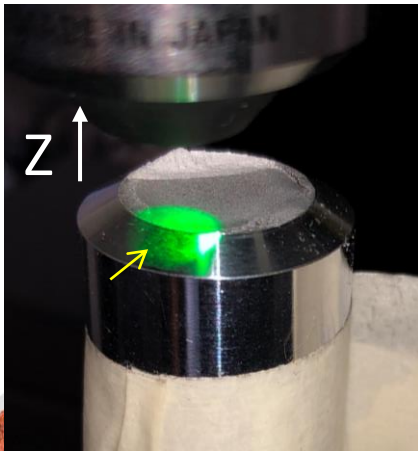

Fatigue crack not at the notch bisector plane

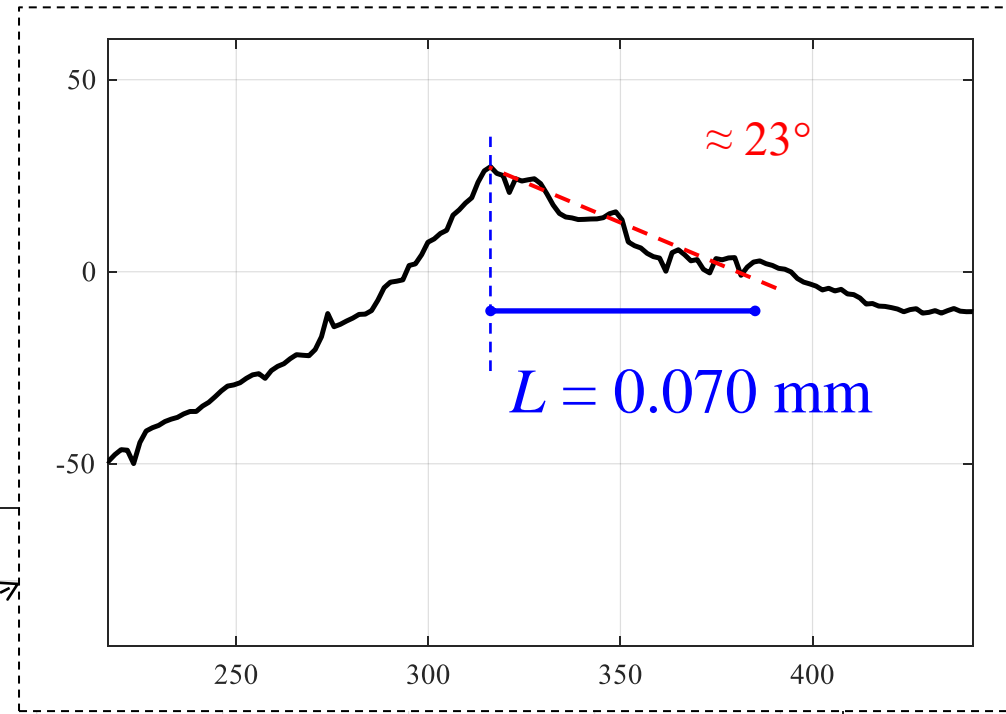
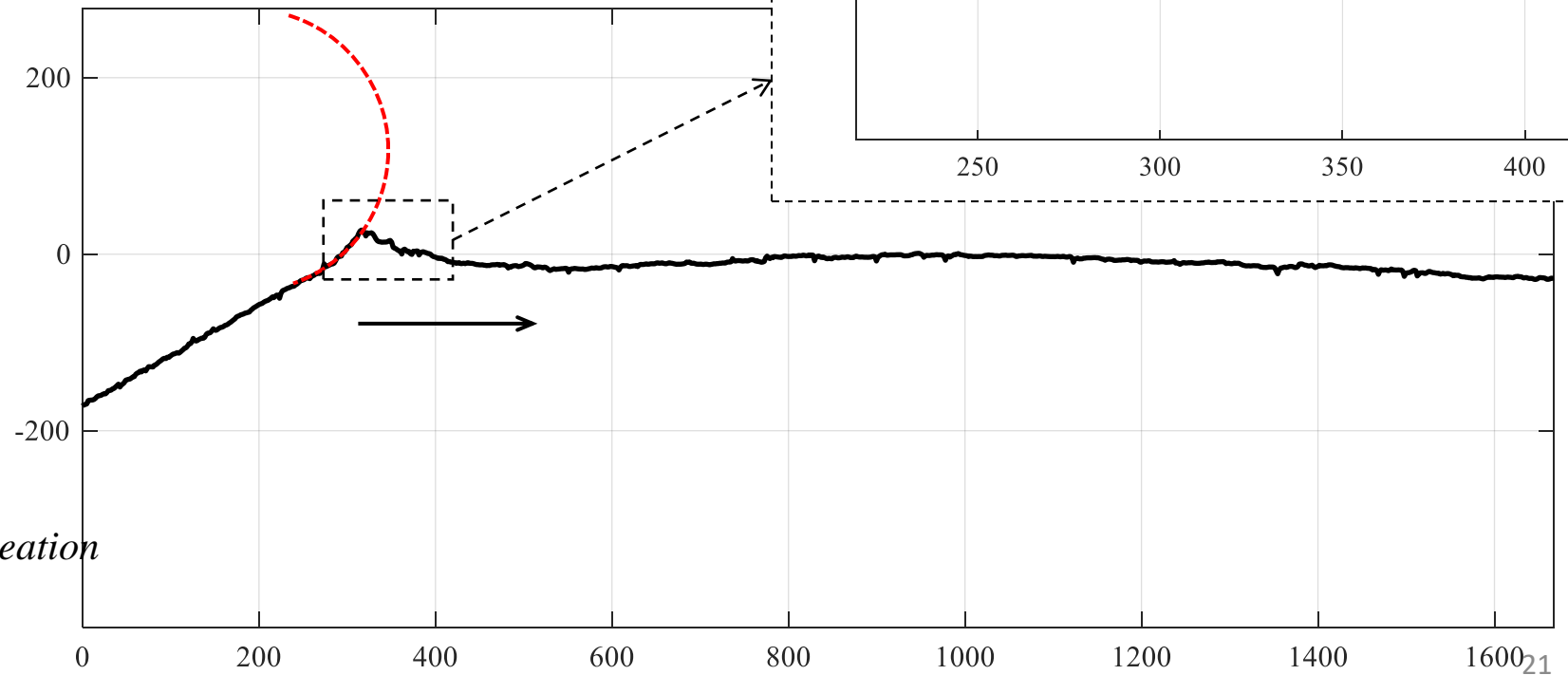

Alum. alloy 7075-T6, Mode III, fracture surface investigation

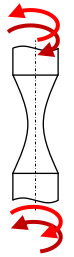

PIII = Plain mode III

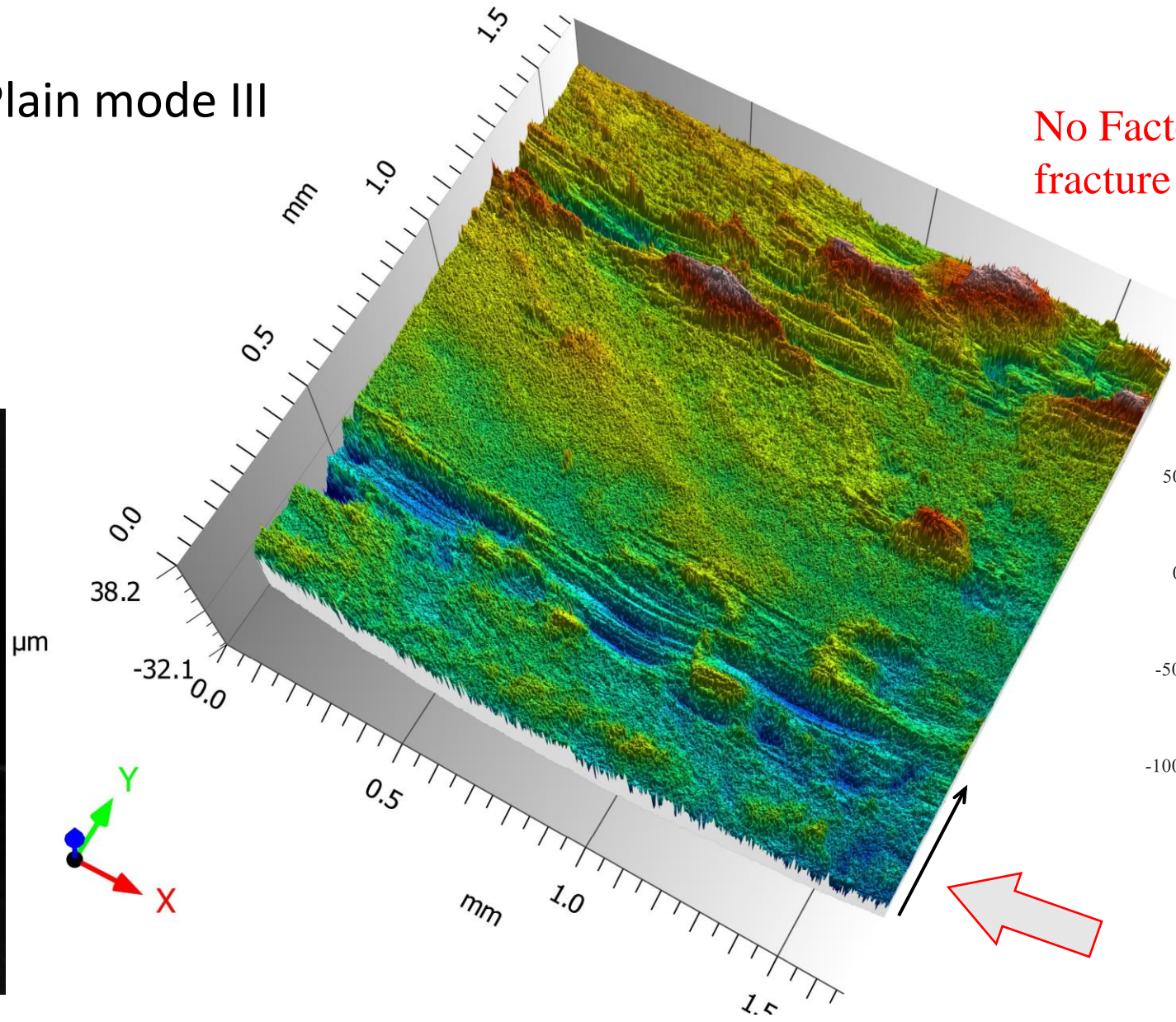

No Factory-Roof fracture surface

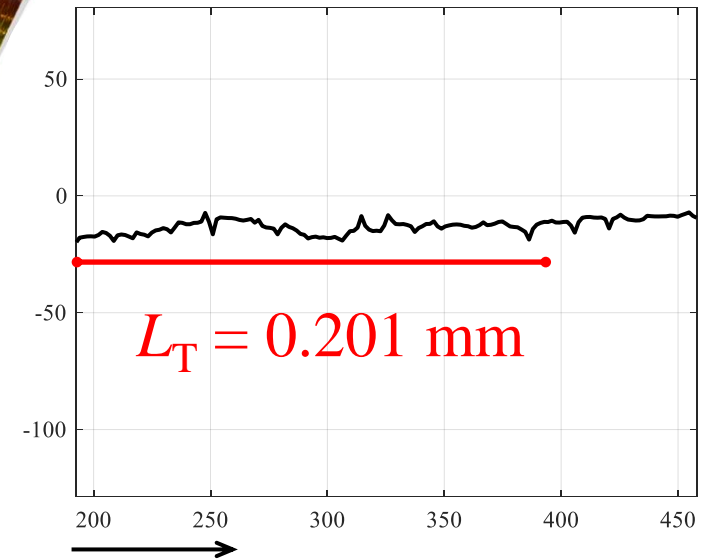

Alum. alloy 7075-T6, Mode III, fracture surface investigation

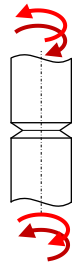

PIII = Notched mode III

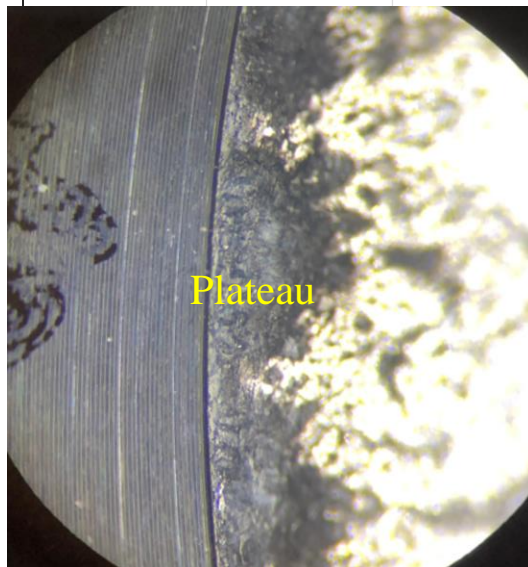
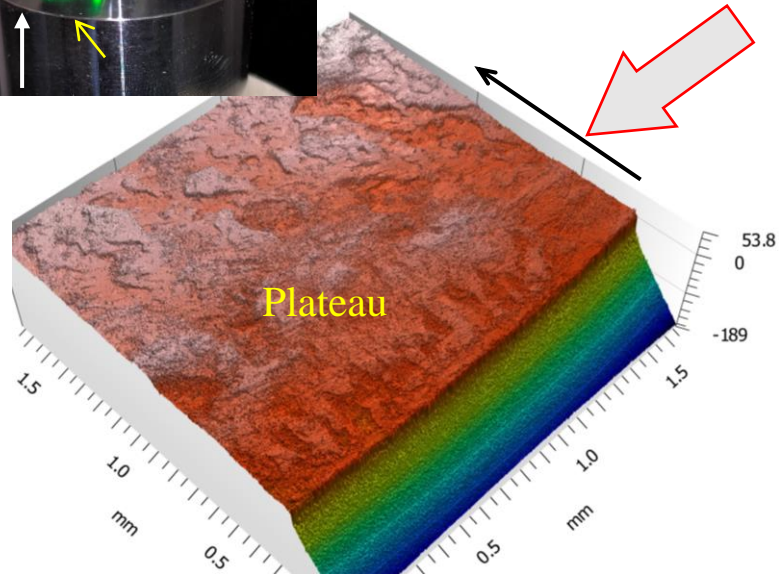
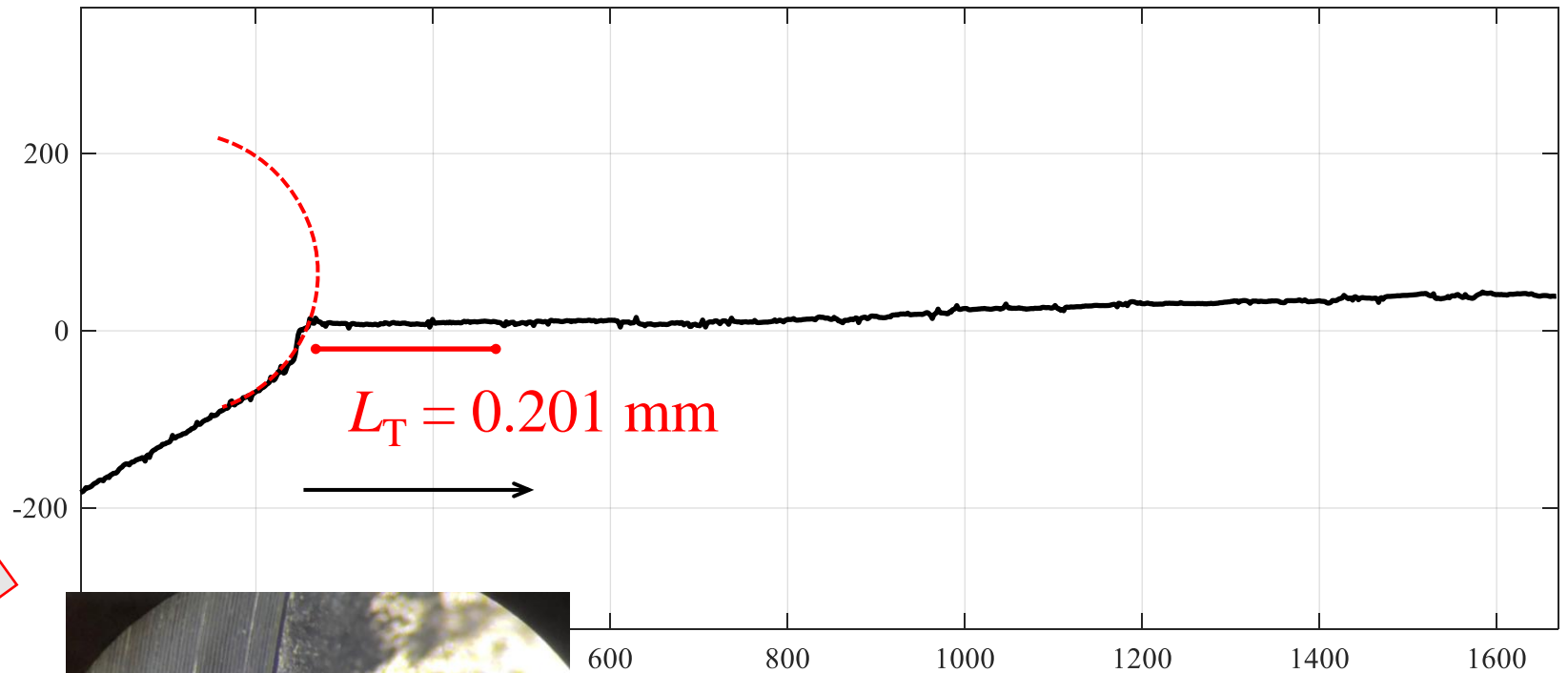
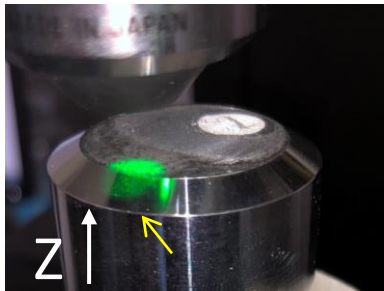

Very limited
Factory-Roof
formations

Conclusions

Interesting application of fracture surface investigation with optical (contactless) profiler

Accurate resolution both in-plane and along the vertical direction

Limited span, and max. slope, for complex (not planar) surfaces

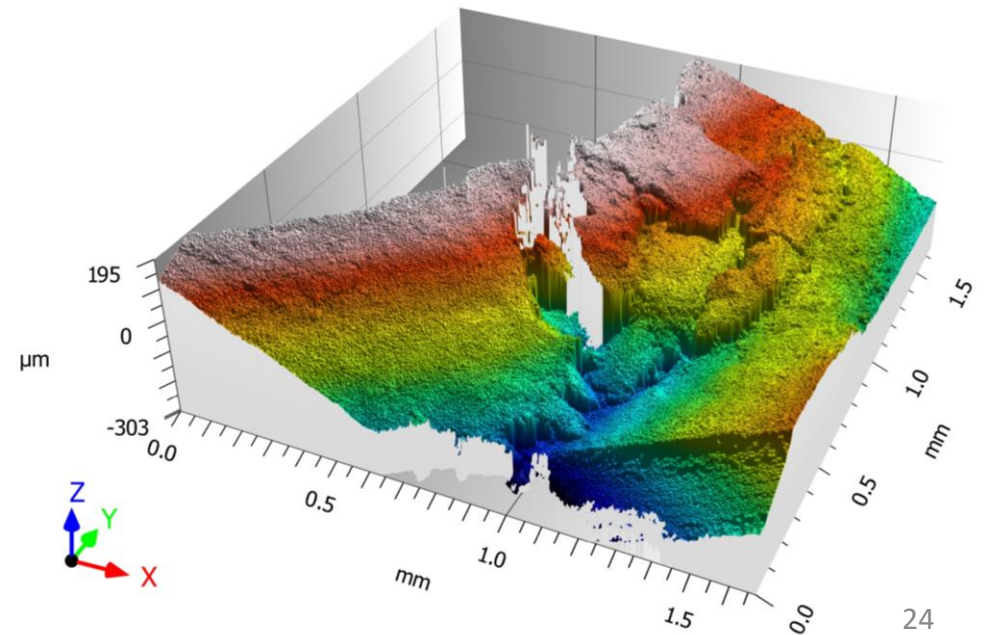

Conclusions

--Steel 42CrMo4--

Mode I:

Planar initiation, within the Crit. Dist.

Mode III:

Planar initiation & evident Factory-Roof

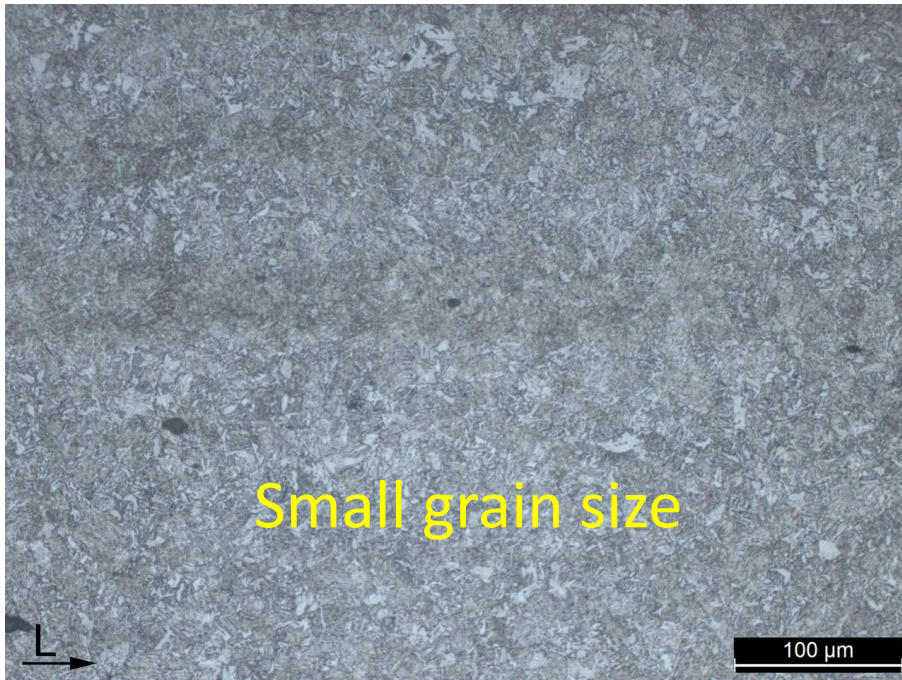

--Aluminium alloy 7075-T6--

Mode I:

More irregular fracture surfaces, and not at the middle plane

Mode III:

Planar initiation & no Factory-Roof feature

